

The Journal of The Royal Astronomical Society of Canada

Journal

Le Journal de la Société royale d'astronomie du Canada

PROMOTING
ASTRONOMY
IN CANADA

April/avril 2014
Volume/volume 108
Number/numéro 2 [765]

Inside this issue:

Earth's Trojan Asteroid

Canada and the 1833
Leonids

AstroNuts Going Strong

Eclipse Crossword Answers

Galaxy Crossword

Should We Colonize Mars?

*Pirate's Treasure Chest
in Canes Venatici*

Astrophotographers take note!

This space is reserved for your B&W or greyscale images. Give us your best shots!

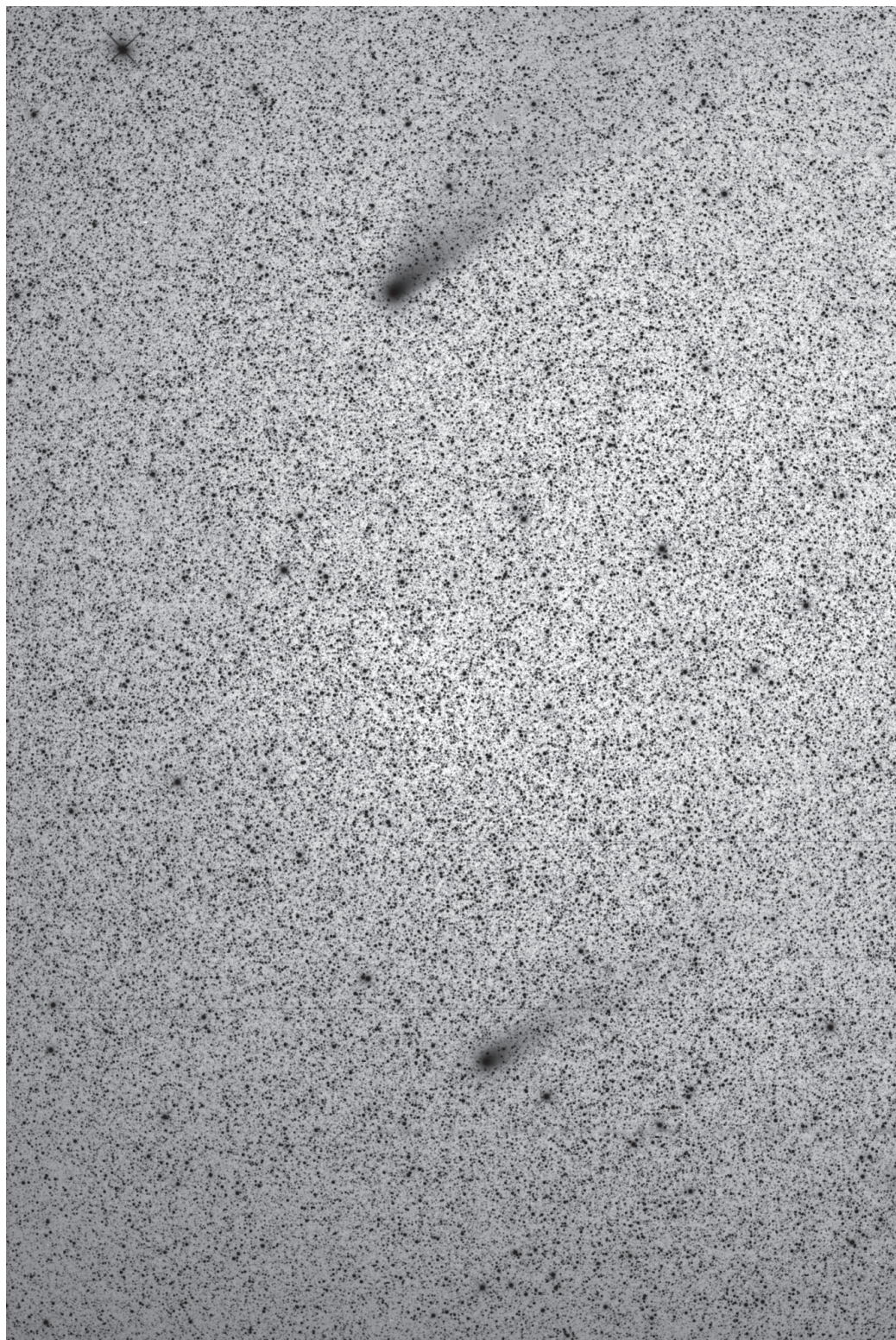

It has been a great fall and winter for comets but by February, the last of the icy snowballs was fading away into the distant Solar System. Before they departed however, Comets Lovejoy and Linear came together for this group photo. Paul Mortfield and Sandy Barnes combined efforts to provide this image (inverted to better show the tails) of the two travellers on February 5. The image was acquired with Sandy's Takahashi FSQ106 f/5 530-mm refractor and an SBIG STL11000 CCD camera at his "Blue Sky Observatory."

contents / table des matières

Feature Articles / Articles de fond

- 54 **The Discovery of Earth's Trojan Asteroid**
by Martin Connors, Paul Wiegert, Amy Mainzer, Brian Martin, and Christian Veillet
- 66 **Canada and the 1833 Leonids**
by Clark Muir
- 73 **AstroNuts Going Strong**
by Ray Bielecki
- 74 **Should We Colonize Mars?**
by Michael Gainer
- 79 **Galaxy Crossword**
by Naomi Pasachoff
- 91 **Answers to February's Eclipse Crossword**
by Naomi Pasachoff

Columns / Rubriques

- 70 **Pen and Pixel: M82 / Cocoon Nebula / M63 / M33**
Eric Benson / Steve McKinney / Tom Zaranek and Paul Mortfield / Richard Henderson
- 76 **Astronomical Art & Artifact: Reverse Engineering an Astronomical Image**
by R.A. Rosenfeld
- 80 **Cosmic Contemplations: No Requiem for a Cassegrain Reflector**
by Jim Chung
- 83 **John Percy's Universe: Toronto's Astronomical Heritage**
by John R. Percy
- 86 **Second Light: Into the Mixing Bowl**
by Leslie J. Sage
- 88 **Fun With Arduinos—Part 1**
by Rick Saunders

Departments / Départements

- 50 **News Notes/En manchettes**
Compiled by Jay Anderson
- Supernova in M82
 - *Gaia* Comes into Focus
 - Smack! Another Martian Crater
 - Back to the Beginning
 - Finally, a Jet in the Milky Way
 - *Rosetta* Spacecraft Raring to Go
- 85 **It's Not All Sirius—Cartoon**
By Ted Dunphy
- 87 **2014 General Assembly Call for Papers**
- 91 **The 2014 General Assembly in Victoria, B.C.**
- 91 **Society News**
by James Edgar
- 92 **Astrocryptic & February Answers**
by Curt Nason

Front Cover — Messier 3, a globular cluster in Canes Venatici, is one of the best-known globulars to both scientists and amateur astronomers. This image, from Kerry-Ann Lecky Hepburn, shows the half-million stars in the cluster in glowing colours, resembling a pirate's treasure chest, opened for viewing. Kerry-Ann used an AstroTech 8" Ritchey-Chrétien telescope and an SBIG 8300 camera. Exposure was 100 minutes in L and 50 minutes each in RGB.



Journal

The *Journal* is a bi-monthly publication of The Royal Astronomical Society of Canada and is devoted to the advancement of astronomy and allied sciences.

It contains articles on Canadian astronomers and current activities of the RASC and its Centres, research and review papers by professional and amateur astronomers, and articles of a historical, biographical, or educational nature of general interest to the astronomical community. All contributions are welcome, but the editors reserve the right to edit material prior to publication. Research papers are reviewed prior to publication, and professional astronomers with institutional affiliations are asked to pay publication charges of \$100 per page. Such charges are waived for RASC members who do not have access to professional funds as well as for solicited articles. Manuscripts and other submitted material may be in English or French, and should be sent to the Editor-in-Chief.

Editor-in-Chief

Jay Anderson
203 – 4920 Dundas St W
Toronto ON M9A 1B7, Canada
Email: editor@rasc.ca
Web site: www.rasc.ca
Telephone: (416) 924-7973
Fax: (416) 924-2911

Associate Editor-in-Chief

Nicole Mortillaro
Email: nmortillaro@gmail.com

Associate Editor, Research

Douglas Hube
Email: dhube@phys.ualberta.ca

Associate Editor, General

Michael Attas
Email: attasm@aecl.ca

Assistant Editors

Michael Allen
Martin Beech
Dave Chapman
Ralph Chou
Ralph Croning
Dave Garner
Patrick Kelly
Gail Wise

Editorial Assistant

Suzanne E. Moreau
Email: semore@sympatico.ca

Production Manager

James Edgar
Email: james@jamesedgar.ca

Contributing Editors

Jim Chung (Cosmic Contemplations)
John Crossen (Rising Stars)
Ted Dunphy (It's Not All Sirius)
Geoff Gaherty (Through My Eyepiece)
Dave Garner (On Another Wavelength)
Blair MacDonald (Imager's Corner)
Curt Nason (Astrocryptic)
Andrew I. Oakes (News Notes)
John R. Percy (John Percy's Universe)
Randall Rosenfeld (Art & Artifact)
Leslie J. Sage (Second Light)
Rick Saunders (Cheap Stuff From China)
David Turner (Reviews)

Proofreaders

Ossama El Badawy
Margaret Brons
Angelika Hackett
Terry Leeder
Kim Leitch
Suzanne Moreau

Design/Production

Michael Gatto, Grant Tomchuk
Email: gattotomatto@eastlink.ca,
granttomchuk@eastlink.ca

Advertising

Melissa Mascarin
Email: mempub@rasc.ca

Printing

Canselmdc
www.cansel.ca

The *Journal* of The Royal Astronomical Society of Canada is published at an annual subscription rate of \$93.45 (including tax) by The Royal Astronomical Society of Canada. Membership, which includes the publications (for personal use), is open to anyone interested in astronomy. Applications for subscriptions to the *Journal* or membership in the RASC and information on how to acquire back issues of the *Journal* can be obtained from:

The Royal Astronomical Society of Canada
203 – 4920 Dundas St W
Toronto ON M9A 1B7, Canada
Email: nationaloffice@rasc.ca
Web site: www.rasc.ca
Telephone: (416) 924-7973
Fax: (416) 924-2911



Canadian Publications Mail Registration No. 09818

Canada Post: Send address changes to 203 – 4920 Dundas St W, Toronto ON M9A 1B7

Canada Post Publication Agreement No. 40069313

We acknowledge the financial support of the Government of Canada through the Canada Periodical Fund (CPF) for our publishing activities.

Canada

© 2014 The Royal Astronomical Society of Canada.

All rights reserved. ISSN 0035-872X



News Notes / En manchettes

Compiled by Jay Anderson

Supernova in M82

On January 21, a group of undergraduate astronomy students at University College London (UCL) serendipitously discovered a supernova in the well-known galaxy M82 in Ursa Major (Figure 1, Pen & Pixel, page 70). Their instructor, astronomer Steve Fossey, was showing them how the CCD camera worked on the university's 35-cm telescope, using M82 as a convenient target in a largely cloudy sky. Fossey perceived an out-of-place star close to the nucleus of the galaxy while he was adjusting the telescope, and he and the students rushed to get several images before the clouds closed in.

The International Astronomical Union later confirmed the discovery, giving the supernova the designation SN 2014J. Ongoing observations identified the supernova as Type 1a—an exploded white dwarf, considerably reddened by the dust and gas in the centre of the galaxy. The supernova appears to have peaked in brightness on February 3 at magnitude 10.5 in visual wavelengths. The initial explosion seems to have occurred on January 14 or 15.

The Royal Astronomical Society of Canada

Vision

To inspire curiosity in all people about the Universe, to share scientific knowledge, and to foster collaboration in astronomical pursuits.

Mission

The Royal Astronomical Society of Canada (RASC) encourages improved understanding of astronomy for all people, through education, outreach, research, publication, enjoyment, partnership, and community.

Values

The RASC has a proud heritage of excellence and integrity in its programs and partnerships. As a vital part of Canada's science community, we support discovery through the scientific method. We inspire and encourage people of all ages to learn about and enjoy astronomy.



Figure 1 — Paul Mortfield of the Toronto Centre photographed M82’s supernova on January 23 from his telescope at Sierra Remote Observatories.

At about 11.5 Mly, SN 2014J is the closest Type 1a supernova spotted since 1972. Spectral observations and its orange colour suggest that it lies behind a considerable volume of interstellar dust and gas—not surprising given the explosive appearance of its parent galaxy. It’s not necessarily an unfortunate positioning. According to *Nature* magazine “M82’s proximity means that there are many existing images of it, pre-explosion, including some from the *Hubble Space Telescope*. Cao and others will comb through those images, looking for what lay in the region before. It will not be easy: M82 is filled with dust. But the light the supernova shines on the dust could teach astronomers something about the host galaxy, too.”

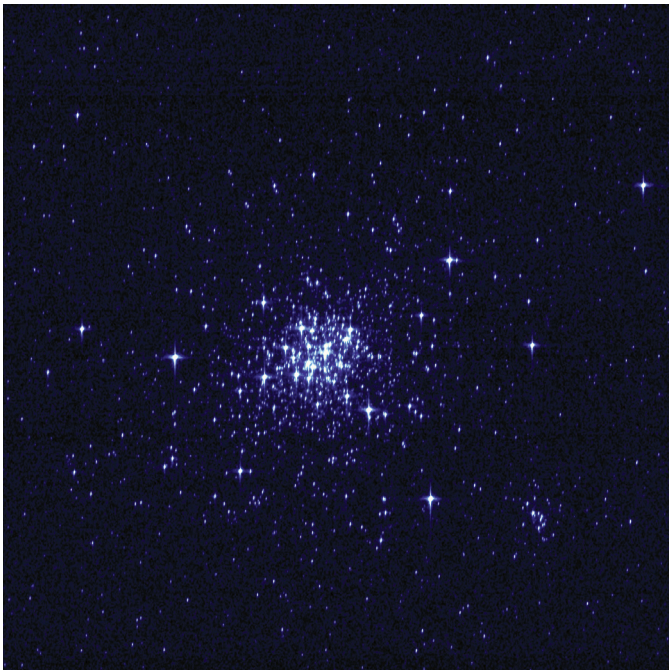

Figure 2 — NGC 1818 in the Large Magellanic Cloud, part of a test image taken during commissioning of the Gaia payload. The image is about 2½ arcminutes on a side, less than 1 percent of the full Gaia field of view. Image: ESA/DPAC/Airbus DS.

Gaia Comes into Focus

The European Space Agency’s *Gaia* spacecraft is evolving toward operational status as engineers bring its optical system into focus. *Gaia* was launched on December 19 and is designed to make the most accurate map yet of the Milky Way from its orbital position near the L_2 Lagrangian point. The satellite will make repeated observations of approximately a billion stars—1 percent of those in our galaxy—viewing each of them an average of 70 times over the next five years to determine their precise motions and positions. These measurements will allow an accurate determination of stellar motions and distances within the Milky Way. In addition to its dynamical measurements, *Gaia* will also measure the brightness, temperature, and chemical composition of the target stars.

Gaia’s design is optimized for precise measurements: rectangular pixels are matched to a pair of rectangular telescope mirrors. For maximum sensitivity, the cameras are not equipped with filters, but instead collect a wide spectrum of electromagnetic energy. Colours and spectral properties are collected by other instruments.

Smack! Another Martian Crater

Images acquired by the High-Resolution Imaging Science Experiment (HiRISE) camera on the *Mars Reconnaissance Orbiter* on November 19 revealed a fresh 30-metre-wide impact crater just north of the planet’s equator. The area was targeted after low-resolution survey cameras indicated that a change in appearance had occurred in the area between July 2010 and May 2012.

The crater is surrounded by a rayed blast zone that has a blue appearance in Figure 3 because of the removal of the reddish dust that normally covers the scene. The explosions threw ejecta as far as 15 km from the impact site. Previous observations of

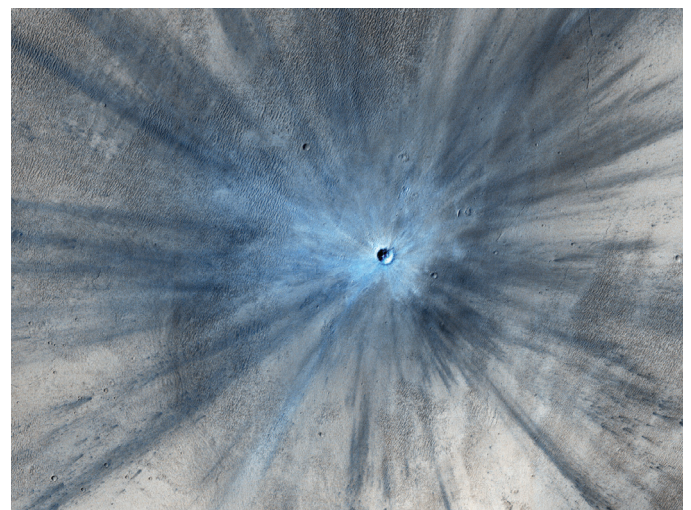

Figure 3 — A blue-toned fresh impact crater dominates this image taken by the HiRISE camera on NASA’s Mars Reconnaissance Orbiter. Image: NASA/JPL-Caltech/Univ. of Arizona

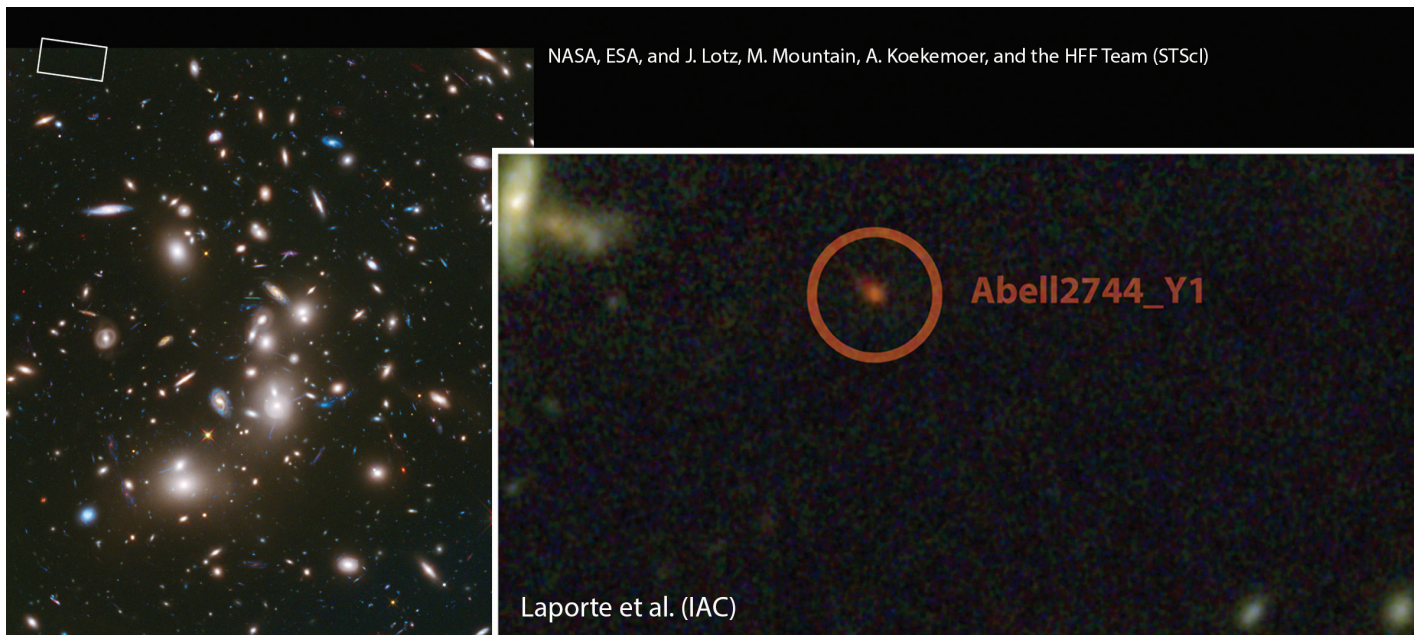

Figure 4 — A deep image of the cluster Abell 2744 acquired by the Hubble Space Telescope (left) and an enlargement of the distant galaxy Abell2744_Y1 (right). Credit: NASA, ESA, and J. Lotz, M. Mountain, A. Koekemoer, and the HFF Team (STScI) Nicolas Laporte et al. (IAC)

other fresh impact sites have indicated that impacts producing craters at least 3.9 metres in diameter occur at a rate exceeding 200 per year across the planet, though few of the scars are as dramatic in appearance as that in Figure 3.

Back to the Beginning

An international team of scientists has used data collected by the *Hubble* and *Spitzer Space Telescopes* to identify one of the most distant galaxies found to date. The galaxy was found in the field of the Abell 2744 galaxy cluster and lies at a distance of 13 Gly, a distance evidenced by its deep red colour. The galaxy is seen as it existed only 658 million years after the Big Bang. Its redshift of 8 is larger than the previous record holder's 7, but smaller than some less-certain candidates with redshifts up to 11.

The observations of Abell 2744 is a part of the “Hubble Frontier Fields” program in which *Hubble*, *Chandra*, and *Spitzer* will spend a large amount of time observing just six galaxy clusters. The goal is not only to learn more about the clusters, but to use their gravitational lensing to find and characterize background galaxies at the edge of the observable Universe. Gravitational lensing gives the HST the observing power of a telescope with a collecting area several hundred times larger.

The *Spitzer Space Telescope* used its infrared-observing capabilities to examine the internal structure of the new galaxy, revealing that the new record holder contains a large amount of gas along with its wellspring of new stars. It is about 30 times smaller than our Milky Way, but is birthing at least 10 times more stars.

Abell 2744 was apparently formed when four smaller clusters merged with each other, giving it the nickname “Pandora’s Cluster” for its mixture of spiral and elliptical galaxies. The combination of *Hubble* and *Spitzer* also identified other distant galaxies lying between redshifts of 6 and 7. The *Hubble* observation revealed more than 3000 background galaxies, smeared, stretched, and magnified by gravity, behind those in the foreground. Background galaxies are magnified 10 to 20 times by the immense gravity of Abell 2744.

Finally, a Jet in the Milky Way

Other galaxies have ‘em—why not us?

Jets, that is. Past observations of the centre of our galaxy have hinted at a jet, but the various results were contradictory and the jet candidates didn’t line up with each other. Now, new combined observations by the *Chandra Space Telescope* and the Very Large Array (VLA) in New Mexico seem to have put an end to the uncertainty. The new observations show that the spin axis of the Milky Way’s core (known as Sagittarius A* or Sgr A*) is pointing in a direction parallel to the galaxy’s spin axis. To astronomers, this indicates that dust and gas have provided a steady diet for the core for the past 10 billion years. If our galaxy had collided with other large galaxies in the recent past, and central black holes had merged, the spin axis could adopt any orientation.

The emerging jet collides with gas lying near Sgr A*, producing X-rays that were detected by *Chandra* and radio emission that were observed by the VLA. The X-ray emission shows a line of high-energy-emitting gas that points back to

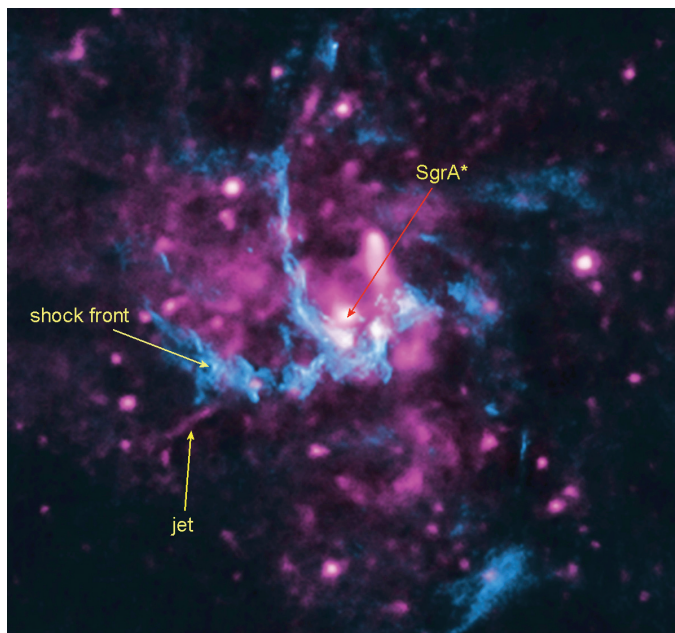

Figure 5 — A composite image of Sgr A* made by the Chandra Space Telescope and the Very Large Array. The X-ray signal is shown in purple; the radio image in blue. The jet is the narrow purple feature extending downward in the image; the blue feature arcing across the middle of the image is a shock front, perhaps suggesting another outflow from Sgr A*. Image: X-ray: NASA/CXC/UCLA/Z. Li et al.; radio: NRAO/VLA

the galaxy core; the radio signal reveals a shock front where the jet collides with the surrounding gas. Jets are produced by the ejection of excess material falling into a black hole, and since our galaxy is consuming very little material, the jet is weak and difficult to find. An opposing jet is not visible, perhaps because of intervening dust and gas or a lack of fuel. Nevertheless, the X-ray spectrum of the jet resembles those of more active supermassive black holes in other galaxies. And, while the jet in the Milky Way is quiet now, other observations have shown that it was much more active in the recent past.

Energetic jets are common throughout the Universe, on scales from individual stars to massive galaxies—wherever black holes are found. They carry excess energy away from the black holes, and their energy, when fed back into the interstellar medium, limits the collapse of gas clouds and the formation of new stars. Sgr A*'s jet may be responsible for giant bubbles of particles jutting out from the Milky Way, features that were discovered by the *Fermi Gamma Ray Telescope* in 2008.

The *Chandra* observations were made between 1999 and 2011 by a team led by first author Zhiyuan Li of Nanjing University in China.

Rosetta Spacecraft Raring to Go

As we reported in the February News Notes, the *Rosetta* spacecraft has awakened from a planned 30-month-long slumber and is in good health, getting ready for a rendezvous with Comet Churyumov-Gerasimenko in August. Engineers

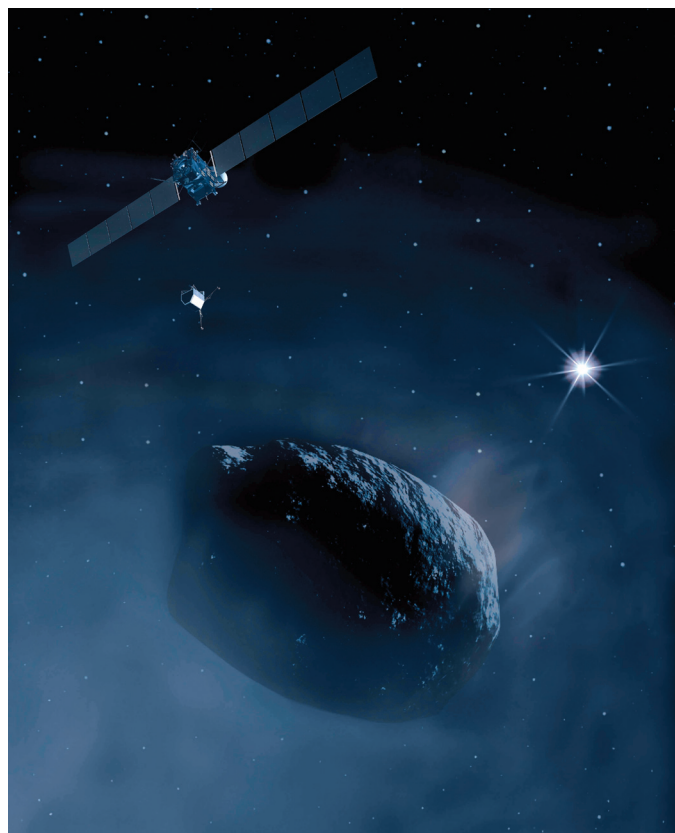

Figure 6 — An artist's impression of Rosetta approaching Comet Churyumov-Gerasimenko and releasing the lander Philae to the surface. Image: AFP/Getty Images

at the European Space Agency have established full control over the space probe and have tested the power, communication, propulsion, and attitude-control systems. Solar panels are delivering plenty of energy and three of the four reaction wheels have been tested and are controlling the spacecraft's orientation. One of the three has some anomalous behaviour, but this was known before the spacecraft was put into hibernation. The reserve reaction wheel also has problems, but new software on board the probe will allow the mission to continue on only two reaction wheels. A previously discovered leak in the helium-pressurization system has been brought under control by running *Rosetta*'s thrusters at lower pressure. Science instruments will not be tested until they are powered up in late March.

Rosetta will become the first spacecraft to orbit a comet when it meets with Churyumov-Gerasimenko late this summer and begins a year of close-in observations. *Rosetta* will approach the comet from the sunward side where it should encounter less dust, as Churyumov-Gerasimenko, if it follows past behaviour, will already be active by the time spacecraft orbit is achieved. In November, *Rosetta* is scheduled to release a German-built lander that will fasten onto the comet and drill into its interior. In July 2015, Churyumov-Gerasimenko will round the Sun, activating the plumes of dust and gas on the comet—an event that promises to provide some exciting observations from the *Philae* probe and *Rosetta*. ★

The Discovery of Earth's Trojan Asteroid

Martin Connors, Athabasca University (martinc@athabascau.ca)

Paul Wiegert, Western University

Amy Mainzer, Jet Propulsion Laboratory

Brian Martin, King's University College

Christian Veillet, Canada-France-Hawaii Telescope (now at Large Binocular Telescope)

Abstract

Trojan asteroids share the orbit of an associated planet by moving slowly about one of the two Lagrangian points that are located 60° ahead of or behind the planet, along its orbit, as measured from the Sun. This orbital configuration was proposed in 1772 by Lagrange as a solution for the motion of three bodies. The first Trojan asteroid was discovered, associated with Jupiter, in 1906. Many thousands of Jovian Trojans are now known to exist, several for Mars and Neptune, and one for Uranus. With calculations showing that Earth could have stable associated Trojans, but with observations being very difficult, it is only in 2010 that the first Earth Trojan was discovered. That body, 2010 TK₇, has an extreme form of Trojan orbit that allows it to move far from the L₄ Lagrangian point with which it is associated, and sometimes even to jump to the other Lagrangian point. The circumstances of discovery, dynamical behaviour, and context are discussed.

Résumé

Les astéroïdes troyens partagent l'orbite d'une planète associée en se déplaçant lentement autour de l'un des points triangulaires de Lagrange, qui sont situés sur son orbite, à 60° en avance ou en retard de la planète, mesurés par rapport au Soleil. Cette configuration orbitale comme solution pour le mouvement de trois corps fut proposée en 1772 par Lagrange. Le premier astéroïde troyen a été découvert, associé à Jupiter, en 1906. Plusieurs milliers de troyens de Jupiter sont maintenant connus, plusieurs de Mars et Neptune, et un seul d'Uranus vient d'être trouvé. Des calculs montrent que la Terre pourrait posséder des astéroïdes troyens stables, mais les observations sont très difficiles, donc ce n'est qu'en 2010 que le premier astéroïde troyen de la Terre fut découvert. Ce corps, 2010 TK₇, possède une forme extrême de l'orbite qui le permet de se déplacer loin du point L₄ de Lagrange avec lequel il est associé, et même de parfois passer à l'autre point de Lagrange. Les circonstances de découverte, le comportement dynamique et le contexte sont discutés.

Introduction: Workings of the Solar System

The name “Trojan asteroid” seems to interest people by evoking an association with history, myth, and heroism. Yet it is an enigmatic term: in what way can an asteroid, a small celestial body, be “Trojan”? To understand Trojan asteroids, and in particular the recently discovered “Earth Trojan” provisionally named 2010 TK₇, it is useful to delve back into the history of astronomy. This allows us to see how our approach to understanding the dynamics of our Solar System has evolved over time and the recent overlap of astronomy with chaos theory, as manifested intriguingly by our new orbital partner.

Although this brief history of Solar System astronomy is a personal view, fact-checking has been done with Petersen (1993), which is a recommended source, blending history with chaos theory to illustrate modern ways of understanding celestial mechanics. Moulton (1914) also has useful historic notes on the development of the subject to his time, interspersed with the textbook's material on mathematical astronomy.

The early history of astronomy was largely concerned with measurement and timing. The ability to predict seasonal, monthly, and daily cycles had an essential practical role in agrarian societies. Some ancient societies, such as the Babylonians and Chinese, catalogued and predicted planetary motions for astrological purposes. Compared to unpredictable systems like the weather and earth movements, the sky could be understood, which may have given comfort in chaotic lives subject to the vagaries of nature.

There was every reason in ancient times to suppose that all of the motions in the heavens, observed from Earth, were in fact centred on Earth (geocentric). For Earthly beings observing objects held to Earth's surface by gravity and slowed by friction, the local region seems to be a good frame of reference. Geocentric motion was implicit in most ancient theories, most famously codified by Claudius Ptolemy of Alexandria about AD 100. The Ptolemaic system allowed quite accurate calculations, albeit for a limited duration. It formed a mechanistic system that served well for nearly 1400 years.

The “paradigm shift” of Copernicus in stating that the Universe was centred on the Sun rather than on or near the Earth was partly motivated by esthetics (Gribbin, 2002). Copernicus was aware of both ancient and nearly contemporary heliocentric systems (Kuhn, 1957). He proceeded to claim that Earth—long known to be a sphere—by rotating, could explain the daily motion of the heavens. From there to motion of the Earth in space was not a large step. However, Copernicus was also motivated by the desire to make an easier and more accurate computing system, and to resolve some inconsistencies, such as the lack of observed apparent change in size of the Moon, that arose in the Ptolemaic system. His replacement Sun-centred system retained mechanical features,

such as circular motions, from the old system. It did not form part of a dynamical system in which forces needed to act. Our modern understanding is based on forces, mostly the force of gravity.

Perhaps motivated by astrological beliefs (Petersen, 1993), Kepler sought out some driving force for planetary motions in order to get away from the “circles within circles” that characterized both the Ptolemaic and Copernican systems. His parallel quest for more accuracy in the Copernican system was partly based on the high quality of the observational material left to him by Tycho Brahe. His initial breakthrough was to realize that planetary orbits around the Sun could be described by ellipses in a plane with the Sun at one of the foci. This is Kepler’s First Law, and the parameterization of orbits by ellipses (whose characteristics may change slowly in time) is used in describing orbits today. Figure 1 shows the present elliptical orbit of the Earth Trojan asteroid 2010 TK₇ around the Sun. The special nature of this orbit is subtle, and in many ways it has an orbit typical of other asteroids, only nearer to the Sun. Kepler’s Second Law—that within its orbit, a body moves such as to sweep out equal area per unit of time—is also nicely illustrated by this somewhat elliptic orbit. Kepler’s Third Law states that for different orbits, the period of revolution about the Sun is proportional to the 3/2 power of the mean distance from the Sun (often stated in the form $P^2=a^3$). The first two laws were in Kepler’s *Astronomia Nova*, published in 1609, and the Third Law was expounded in *Harmonice Mundi* in 1619. Despite the likely motivation of seeking a force-based or dynamic system, Kepler in the end gave an essentially modern description that did not contain dynamics.

From the point of view of the motion of bodies in the Solar System under the influence of forces, Newton accomplished what had eluded Kepler. Not only was he a co-inventor of calculus, which gave greatly enhanced mathematical tools, but he formulated the law of gravitational force. Kepler’s laws could be derived from it and his laws of motion (Newton’s three laws). Much of this work was presented in the *Principia*, published in 1686, but already in 1684 he had shown that the inverse-square law of gravity led to Kepler’s elliptical orbits (Petersen, 1993). Newton’s solution of the two-body problem, such as the motion of one planet around the Sun, is exact. It remains remarkable that, with the limited exception of the Lagrange three-body solution detailed below, it is the *only* exactly solvable problem in classical gravitational mechanics. Calculus, however, provided a mechanism for approximation, allowing numerical solutions of arbitrarily great precision to general problems of celestial mechanics. Among these may be mentioned the theory of the Moon, whose orbit around the Earth is greatly perturbed by the gravitational influence of the Sun, and that of the planet Uranus, accidentally discovered in 1781 by William Herschel.

Observations, greatly enhanced by telescopes since their invention around 1600, allowed the recognition that the orbit

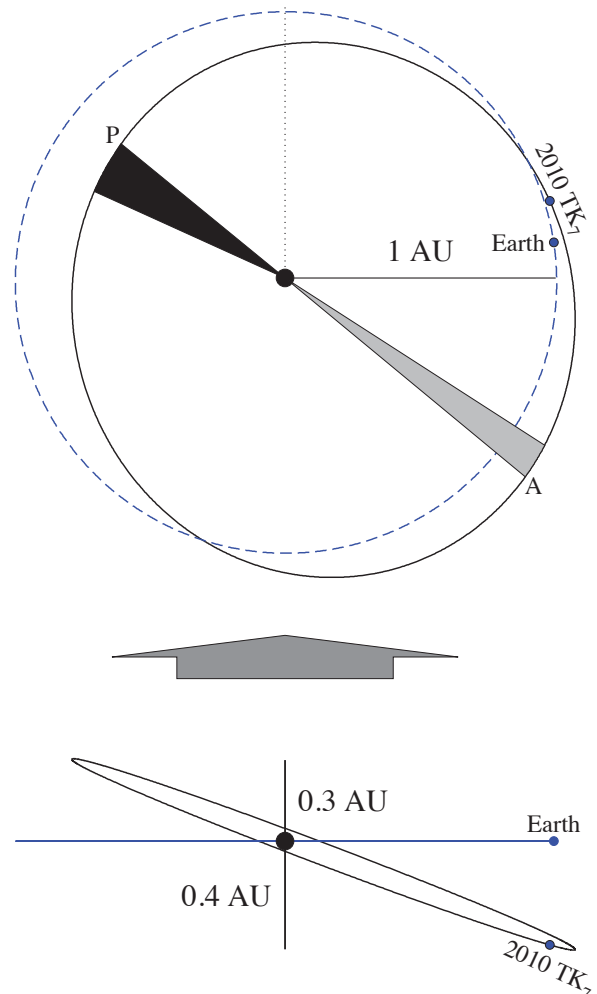

Figure 1 — Views of the orbits of Earth (dashed) and asteroid 2010 TK₇, as seen from above the north ecliptic pole (top) and looking from the side in the direction of the large grey arrow. The X axis is along the solid line 1 AU long on the right. The Y axis follows the dotted line upward. Earth and the asteroid are indicated by dots at their positions at the time of discovery of 2010 TK₇, 2010 October 1. The central dot represents the Sun and the dots are not to scale. Two of Kepler’s laws are illustrated in this figure. The orbits are ellipses in their own plane. Earth’s orbit is very nearly circular. The orbit of the asteroid is more clearly elliptical although slightly distorted when seen from above, and very distorted when seen from the side. In the top view, the aphelion of the asteroid is marked A, and the perihelion P. Ten days of motion are shown near each point. The areas swept out in these equal periods of time, shown by shading (black near perihelion, gray near aphelion) are equal by Kepler’s Second Law, the *law of areas*. The speed of a body must thus be larger near perihelion. In the bottom panel, the inclination of 2010 TK₇ with respect to Earth’s orbit is clear, allowing excursions of roughly 0.3 and 0.4 AU above and below the plane.

of Uranus was affected, or perturbed, by some unknown body. The growing body of observations, coupled with advances in computational mathematics, led to the prediction of the existence of a perturbing body, and the discovery of the planet Neptune in 1846. The predictions may have been erroneous and the discovery in some ways fortuitous (Petersen, 1993),

but the discovery of Neptune was still a triumph of celestial mechanics, and the years near 1800 stand as a golden age of mechanistic astronomy. Green (1999; p. 341) cites the great French mathematician and astronomer Laplace as stating that if all the forces and data were available for analysis “nothing would be uncertain, and the future, like the past” could be precisely predicted. Quantum mechanics imposed a vastly different, probabilistic worldview, starting about 1900, with most differences being on the microscopic scale. However, even in celestial mechanics, the lack of exact knowledge of initial conditions, and accumulation of small errors, make Laplace’s mechanistic view of planetary dynamics break down due to chaotic effects (Lecar *et al.*, 2001; Wisdom, 1987).

An elegant insight of mechanistic astronomy, relevant to the Trojan asteroid problem, derived from the study of the motion of the Moon. Joseph Louis Lagrange (1736-1813) was born in Turin, Italy, into a French family. His later career as a mathematician and *géomètre* (practitioner of celestial mechanics) unfolded in Berlin and Paris. He responded to a call by the Paris Academy in 1772 for a contest “perfecting the methods on which the lunar theory is founded” (Wilson, 1995). The complex motion of the Moon under the influence of both Earth and Sun (*i.e.* a three-body problem) had great practical interest, with applications in navigation and surveying.

Lagrange’s more general approach to the theory of three bodies led to a prize-winning entry entitled *Essai sur le problème des trois corps* (Lagrange, 1772). Lagrange’s solution did not require the third body to be of negligible mass, and gave two classes of solution involving special points now known as *Lagrangian Points*. The geometry is shown in Figure 2. In one class, the three bodies could be along the same line (collinear). What came to be called the L_1 and L_2 points are located near the planet, and these are of modern technological use for satellites. The third collinear point, L_3 , is found on the opposite side of the Sun from the planet. The collinear points are not stable: spacecraft need to actively control their position to stay near them. Earth Trojan asteroid 2010 TK₇ is the first body known to be able to temporarily reside at L_3 (Connors *et al.*, 2011). The other class of solution has the smaller bodies at positions forming an equilateral triangle with the planet and Sun; in other words, as viewed from the Sun, these positions are 60° ahead of or behind the planet in its orbit. The point leading the planet in its counterclockwise (viewed from the north) path around the Sun is called L_4 , and that following the planet is called L_5 . These triangular points allow stable motion of a small body under the influence of the Sun and planet. Since they are very near the planet’s orbit, and the small third body stays near them, the orbit is “shared” at least on average, and the motion is referred to as “co-orbital.”

As envisaged by Lagrange, these solutions were elegant: an abstract, mechanical picture of perfection. Comets were known, but their known orbits at the time¹ would not have led

Lagrange Points for Mass Ratio 0.03

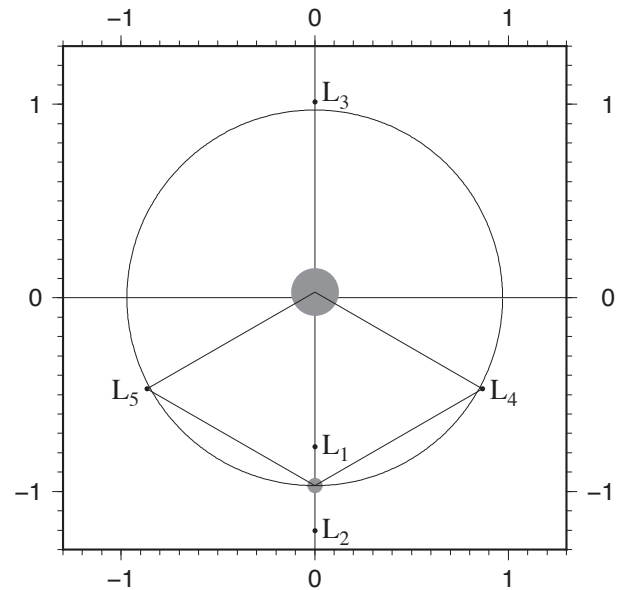

Figure 2 — Geometry of Lagrangian points. The five Lagrangian points are located in space relative to the planet (lower black dot), as it orbits a star only 33 times more massive (larger dot near origin), as seen in a frame revolving with the planet. In this co-rotating frame, the planet is considered stationary so that motion may be shown with respect to it. The inner Lagrangian point L_1 is inward of the planet, the outer one L_2 further from the star. The opposite Lagrangian point L_3 is on the other side of the star. The L_4 and L_5 triangular points are the corners of equilateral triangles with the star and planet, and are seen as 60° from the star if viewing from the planet. Trojan asteroids can remain near these points, but generally are not exactly at them. The planet orbits the origin (centre of mass) on a circle of scaled radius 1, and the star also orbits this point, but on a small circle that is not shown.

one to expect them to be found at Lagrange points. Asteroids were discovered only in 1801, 29 years after Lagrange’s publication. Thus, Lagrange regarded his special solutions as purely of theoretical interest (“*Cette recherche n’est à la vérité que de pure curiosité*”) and not existing in the real Universe (“*ces cas n’aient pas lieu dans le Système du monde*”). He was not to be disproved until 1906, when the first Trojan asteroid was discovered, associated with the planet Jupiter.

Trojan Asteroids

The first minor planet was discovered on 1801 January 1, by Giuseppe Piazzi in Palermo, Italy (Cunningham *et al.*, 2011). It was subsequently numbered and named 1 Ceres. It is now considered to be a dwarf planet, but retains its asteroid or minor-planet number. The nature of Ceres was subject to debate after its discovery, and it was initially referred to as a “planet” (Cunningham *et al.*, 2011). The term “Planet” was still found in the German asteroid literature over a century later. After William Herschel found the second asteroid Pallas in

1802, the term “asteroid” came into use for these objects, which were of star-like appearance even in his telescope, large for the era (Cunningham *et al.*, 2009; Cunningham and Orchiston, 2011). As the 19th century advanced, it was found that large numbers of such bodies existed, mainly in a zone between the orbits of Mars and Jupiter.

The Königstuhl Observatory on the small mountain of the same name overlooking Heidelberg was among the world’s foremost in asteroid discovery in the late 19th and early 20th centuries. Astronomer Max Wolf (1863-1932) developed advanced photographic and search techniques using its large refractors and what was for a short while one of the world’s largest telescopes, the 71-cm reflector. This observatory had discovered 316 asteroids by 1914, and in 1913, it found 32 of the year’s 88 new asteroids (Hills, 1914). Wolf’s work spanned many areas of interest in the early 20th century, but a common theme was the efficient application of modern imaging techniques, at that time, photography and plate scanning (Kopff, 1928). Some of Wolf’s early methods are described in English in considerable detail by Holden (1896): by the early 20th century, these techniques had been yet further advanced. Close cooperation with Johann Palisa of the Vienna Observatory allowed rapid visual followup of asteroids discovered photographically and with optomechanical aid by Wolf’s group at Heidelberg (Freiesleben, 1962).

In the course of routine observations on 1906 February 22, Wolf and August Kopff discovered four asteroids (Wolf, 1906a). Wolf himself discovered what was denoted in the system of the time, 1906 TG, drawing attention to its small movement in right ascension. Kepler’s Third Law gives a longer period, and thus smaller motion, for an object near the distance of Jupiter than for the closer main-belt asteroids commonly discovered. At the time of discovery, 1906 TG was nearly in opposition: the anti-sunward region of the sky is optimal for asteroid searches since objects there show near-full phase and are about as near as possible to Earth, making them brighter. In addition, Wolf’s method relied on initially looking for streaks on photographic plates, as at this point, the apparent motion of asteroids is rapid, although retrograde, making a longer streak than at other positions along the orbit. The object was near, but not exactly at, the Jupiter L_4 Lagrangian point, preceding Jupiter by about 70° in their nearly common orbit. This was not apparently realized at the time of discovery, when most asteroids being found were main-belt objects. The second Trojan was found by Kopff among seven new discoveries (Wolf, 1906b) on 1906 October 17, designated initially 1906 VY. It was near opposition and about 40° from Jupiter near the L_5 trailing Lagrangian point. On 1907 February 10, Wolf (1907) discovered 1907 XM, once again near opposition, but about 120° from Jupiter near the L_4 point. The Heidelberg discoverers (Wolf & Kopff, 1907) grouped these unusual asteroids, following a suggestion by Palisa to assign them names from Homer’s *Iliad*, the epic

poem about the Trojan War. Thus arose the term “Trojan” asteroid. Perhaps cautiously, or perhaps not feeling that these bodies corresponded to the Lagrange special solution, the Heidelberg group did not mention the likely connection to Jupiter, noting them as merely “*sonnenfern*” or far from the Sun. By this time, the orbit of 1906 TG had been well enough determined to assign its current number and name as 588 Achilles. 1906 VY was named after Achilles’ dear friend or cousin Patroclus and later assigned the number 617, and 1907 XM was named for their mutual enemy, the Trojan Hector. The latter was later numbered as 624, and its name is now spelled Hektor. Subsequently, asteroids near the Jupiter L_4 point have been named after Greek heroes, and those near L_5 after Trojans. The early naming did not follow this convention, and Trojan hero Hektor is near L_4 , while Greek hero Patroclus is near L_5 . Generically, the Jupiter Lagrange-triangular-point asteroids are now called Trojans. Now that asteroids are known near the Lagrangian points of other bodies, the term is extended by giving the name of the guiding body, as in “Earth Trojan.”

It is unclear to what degree the Heidelberg observers were aware of the three-body solution of Lagrange. Certainly, they were aware of important methods in perturbation theory of asteroids that are an important part of Lagrange’s overall works on celestial mechanics. However, one person was very well placed to interpret the new discoveries: the Scandinavian astronomer Carl Ludwig Charlier. (K.L., 1935). He had recently published on the topic of treatment of the three-body problem with planetary perturbations (citation in Charlier (1906), not available to the present authors) and had just written a two-volume book on celestial mechanics (Charlier, 1902, 1907) that introduced the currently used designations of the triangular Lagrangian points. Already in May 1906, Charlier (1906) noted the great interest of 1906 TG, in that its rate of motion, commented on as slow by the discoverers, was very close to that of Jupiter. He pointed out that it was close to, but not exactly at, a triangular point, but that eccentricity and inclination of orbits would lead one to expect slight differences. He added a description of the epicyclic and librational motions that could be expected to be observed over the long term (the libration has a period of 148 years). These aspects are discussed in more detail below. Finally, he pointed out that 1906 TG could belong to a new class of bodies, and that it would be a good idea to search the other Lagrangian point. Despite the journal of publication, *Astronomische Nachrichten*, being heavily used by astronomers in Heidelberg, it is unclear what degree of credence was given there to Charlier’s rapid and correct interpretation of the situation.

There are now over 5000 Trojan asteroids with relatively well-established orbits. The Lagrange theory is widely known and certain aspects of it are used in space navigation. Trojans are known for all the planets except Mercury, Venus, and Saturn, and even for some asteroids/dwarf planets. We now

pass to the circumstances leading to discovery of Earth's Trojan companion.

Mars Trojans and Assorted Co-orbital Objects

The recognition in 1990 of 5261 Eureka as the first Trojan not associated with Jupiter was described by Innanen (1991) in this *Journal*. Eureka is a fitting name to be associated with something new, and this Mars Trojan seemed to stimulate interest in finding other co-orbital bodies. Similarly, the activity following the Heidelberg discoveries led to interest in the three-body problem, and Brown (1911) extended the idea of co-orbital motion to include “horse-shoe” objects, moving past the L_4 - L_3 - L_5 points (see below). The first Earth co-orbital found (Wiegert *et al.*, 1997, 1998) moves on a complex horseshoe orbit with large inclination. “Quasisatellites” (Connors *et al.*, 2002, 2004) show a more subtle form of co-orbital behaviour, staying near the planet in a relative orbit resembling retrograde satellite motion. In all three cases, the semimajor axis a is very close to that of the planet, epicycles and variation of a take place approximately once per revolution, and longer-term libration makes the annual epicycle move slowly along the orbit. By Kepler's Third Law, if the semimajor axes are the same, so is the period and thus the average rate of progress in the orbit (mean motion): this is referred to as a 1:1 mean motion resonance. The libration can be correlated with small changes in a : when the small body is at slightly larger a , it falls behind in its relative motion, and vice versa.

In the late 20th and early 21st century, various classes of co-orbital companions were found in the inner Solar System. Theoretical and modelling work was also done. Specifically addressing the question of how to search for Earth Trojans, Wiegert *et al.* (2000) found that they should be stable, but in regions close to the Sun in the dawn or dusk skies. This makes ground-based searches difficult, and surveys (Whitely & Tholen, 1998; Connors *et al.*, 2000) with large-scale CCDs were not successful.

Space-Based Asteroid Searches

Observation from space removes atmospheric effects that scatter sunlight and allows the detection of wavelengths of radiation that cannot be observed from the ground. Both can help make asteroids brighter against the background sky and easier to find, even quite near the direction of the Sun. The *Wide Infrared Survey Explorer* or *WISE* (Wright *et al.*, 2010) operated in the infrared (IR), using cryogenic (dual-stage solid hydrogen) cooling, from December 2009 through 2010 September 29; after that, the mission operated without active cooling until 2011 February 1. In 2013, it was revived for passively cooled operation, detecting asteroids under the name *NEOWISE*, which also was the name of the asteroid survey conducted during the prime mission (Mainzer *et al.*, 2011a).

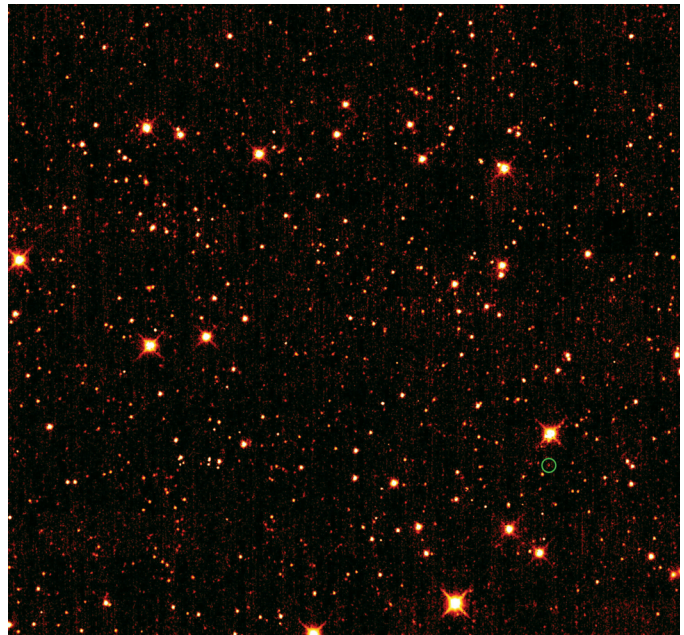

Figure 3 — WISE infrared 4.6 μm wavelength near-discovery image for 2010 TK₇. The asteroid is circled in green at the lower right. This image is centred at RA 6:14:49, Dec. -44:47:32 and is 46×46 arcmin, with south up. The bright star above the asteroid is HD 43327, roughly 10th magnitude in visible light. Faint asteroids are found as moving objects against a background of stars that are usually much brighter than they are. In this case, 2010 TK₇ was about visual magnitude 21, roughly 10,000 times fainter than HD 43327.

WISE discoveries were made public rapidly to several standard sources for information about new asteroids. The reduced orbits are available to researchers who wish to conduct further investigations.

WISE has a telescope of aperture 40 cm, comparable to mid-range amateur telescopes. Despite its modest size, the advantages of operating in space with cryogenic cooling, and detecting asteroids whose thermal emission is bright compared to the background sky, give it a detection capability literally millions of times greater than a comparably sized infrared instrument on the ground. Its mid-IR bands at 3.4, 4.6, 12, and 22 μm wavelengths (the first two of which can be used without coolant) allow detection of IR emission from asteroids, which dominates over reflected sunlight at the longest wavelengths. From a single IR band (plus knowledge of the distance from an orbital solution), asteroid diameters can be derived; the addition of visible-light observations allows determination of the albedo (reflectivity). *WISE* discovered ~150 near-Earth or potentially hazardous asteroids and 21 comets (<http://neo.jpl.nasa.gov/stats/wise/>, cited 2013 November 12). It detected over 158,000 asteroids, of which 34,000 were new discoveries, while it had coolant. This was fully depleted on 2010 September 29 (Mainzer *et al.*, 2012).

On 2010 October 1 (UT), shortly after the coolant ran out, *WISE* first detected 2010 TK₇. Eighteen observations were

taken by *WISE* (a typical image is shown in Figure 3) and 13 more by ground-based observatories immediately following discovery, so that the orbit was reported to have a semimajor axis of 0.9991410 AU on 2010 October 7 (Minor Planet Center, 2010). *WISE* observes always at 90° from the Sun in the sky but with a large declination range. The object was at about -45° declination when discovered, and thus accessible only to Southern Hemisphere telescopes. In the visual band, the red or visual magnitude near the time of discovery was near 21, allowing determination of the asteroidal absolute magnitude, H , as 20.7, which for typical asteroid albedos would indicate a diameter of roughly 300 m (<http://neo.jpl.nasa.gov/glossary/h.html>, cited 2013 November 12). Further study of the two-band *WISE* data allowed Mainzer *et al.* (2012) to confirm this diameter as 380 ± 120 m, with an albedo of $p_v = 0.06$ with large uncertainty. To put the albedo in context

as one of the few indicators of composition of asteroids, the study of a large proportion of the Main Belt asteroids observed with 4-band *WISE* data by Masiero *et al.* (2012) found that there is a dark population with mean albedo of 0.06 present among all asteroids, with a brighter population of mean albedo roughly 0.25 present in the inner and middle asteroid belt. Roughly one third of the near-Earth object population is dark (Mainzer, 2011b; Stuart & Binzel, 2004). 2010 TK₇ has a fairly typical albedo for dark asteroids.

The orbital geometry of 2010 TK₇ is very unfavourable for observations from Earth's surface, as shown in Figure 4. There have been few observations since the time of discovery. It spends most of its time at negative declination: the interplay of the orbital parameters with Kepler's Second Law (as illustrated in Figure 1) ensures this. To make matters worse, Figure 5 shows that the object remains faint at all times, making it visible only in large telescopes (most of which are in the northern hemisphere). Unlike almost all asteroids, it never comes to opposition (elongation of 180°), and usually is close to the Sun.

The scatter in observed magnitude near the time of discovery, shown in Figure 6, observed in the IR by *WISE* and from subsequent ground observations, indicates that the object may be elongated and rotating (perhaps fairly rapidly). With the

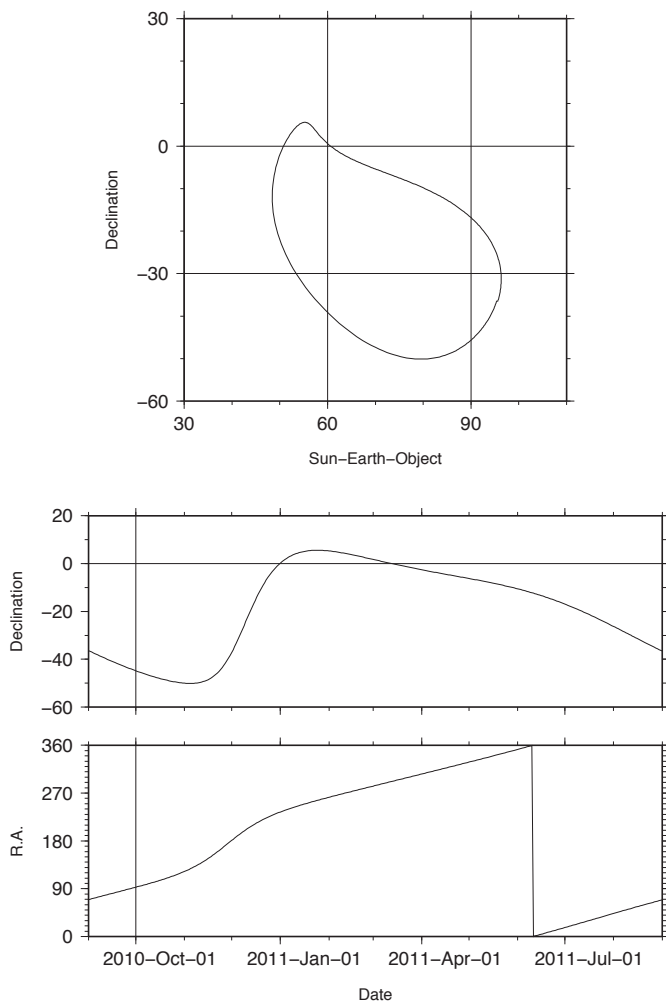

Figure 4 — Ephemeris plots for 2010 TK₇. The bottom panels show the Right Ascension (in degrees) and Declination of the asteroid from 2010 September 1 to 2011 September 1. The date of discovery, 2010 October 1, is marked by a vertical line. Note that the declination is almost always negative. The top panel combines the declination with elongation from the Sun to illustrate the combination of southerly declination and small elongation that make 2010 TK₇ a very difficult object to observe.

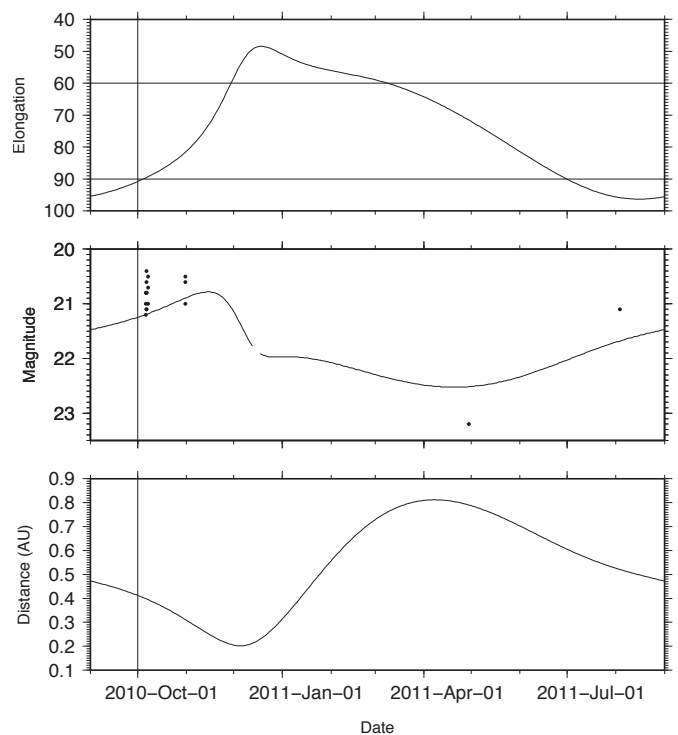

Figure 5 — Position and brightness of 2010 TK₇. The bottom panel shows the distance from Earth in astronomical units (AU). The middle panel shows the predicted optical magnitude, with dots showing observed values. The top panel (compare to Fig. 4) shows the elongation from the Sun. Horizontal lines indicate the value at the time of discovery (90° , bottom line), and the nominal Lagrangian point (60° , top line).

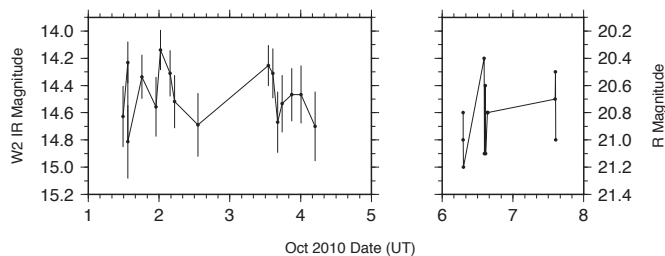

Figure 6 — W2 (4.6 μm) band IR magnitude from WISE (left panel) and ground-based R optical magnitudes (right panel) immediately following the discovery of 2010 TK₇ on 2010 October 1. The range of variation largely exceeds the errors of observation (error bars for WISE, not shown for optical but likely 0.1 to 0.3 mag), implying that the object is elongated. Thirteen optical observations are shown, but some points overlap.

small number of observations, a light curve or other physical information cannot be reliably determined. However, the semimajor axis of very close to 1 AU, determined quickly after its discovery, suggested that 2010 TK₇ could be of dynamical interest, since this is a characteristic of Earth co-orbital asteroids.

Discovery of the Orbital Properties of 2010 TK₇

The discussion in Section 2 above focused on the classical, geometric approach to asteroid stability near Lagrangian points, which explains Trojans well if the strict geometric conditions can be relaxed slightly, as pointed out by Charlier (1906). A more modern, and richer, approach, allowing a connection to chaos theory, emphasizes the role of resonance between asteroids and larger bodies (Lecar *et al.*, 2001). Jupiter, due to its dominant mass among planets, structures much of the asteroid belt through various resonances (including those that produce the Kirkwood gaps), and its large Trojan clouds are the premier example of 1:1 mean-motion resonance. However, 1:1 resonance with other planets, and even with asteroids (Christou and Wiegert, 2012), is possible, Section 3 mentioned Mars Trojans and objects co-orbital with Earth. Being resonant is not necessary even if a is very similar, and the real indication is a long-term libration of some orbital parameter. However, usually an asteroid orbit showing the same semimajor axis as a planet will be interesting and may reward investigation.

The online, sortable, Near Earth Object lists at JPL, available at the site http://neo.jpl.nasa.gov/cgi-bin/neo_elem makes checking for potential co-orbitals easy. This list, as of mid-November 2010, featured two interesting objects: 2010 SO₁₆ and 2010 TK₇, both with a very close to 1, and both discovered by WISE. JPL also provides a service called

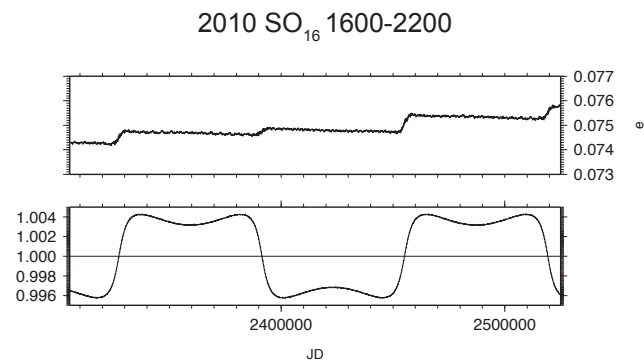

Figure 7 — Orbital parameter survey plot for 2010 SO₁₆. The bottom panel shows the characteristic “square wave” pattern of semimajor axis (a) variation for a horseshoe orbit, and the top panel the eccentricity e of the orbit. The time period is 1600 to 2200 CE, with labelling in Julian Days and axis ticks of 10,000 days.

“Horizons,” which in its telnet form allows easy integration of orbits over several hundred years (Giorgini *et al.*, 1996). Using this, 2010 SO₁₆ was found (see Figure 7) to show classic “square wave” signatures of a libration, with period approximately 400 years, typical of horseshoe objects (Connors *et al.*, 2002). Christou and Asher (2011) did a detailed investigation of its stability, and noted that it is fairly large among Earth co-orbitals, about 300 m in diameter. The pattern of a variation of 2010 TK₇, shown in Figure 8, was more like a “sawtooth” than the characteristic square wave of a horseshoe object. Three-dimensional diagrams clarify the situation, showing the relative orbit in the co-rotating frame. Unlike a standard depiction of an orbit in fixed space as seen in Figure 1, such diagrams plot the position in a frame in which the planet (in this case, Earth) is stationary. As in Figure 2, an ideal Trojan exactly at a Lagrangian point would simply be a point (in the ideal case of circular orbits). In the case of a horseshoe object, as shown for 2010 SO₁₆ in Figure 9, annual motion is an approximately vertical ellipse in this frame. Over the longer-period libration, this ellipse moves around the Sun relative to Earth, tracing out a curved cylinder in three dimensions. The region near Earth is avoided, so that over a long period of time, the trajectory of the asteroid relative to Earth makes a “horseshoe.” The annual motion in an ellipse is the epicycle referred to above, while the longer-term motion is libration. In contrast to the beautiful symmetry of the relative motion plot of 2010 SO₁₆, that of 2010 TK₇ is rather ugly, as shown in Figure 10. However, the asymmetry arises from staying near only one triangular Lagrangian point rather than sweeping out a horseshoe: a property of Trojan asteroids.

Some unusual aspects of 2010 TK₇ in terms of the expected observational properties of Trojan asteroids can be seen in Figure 5. Trojans are loosely expected to be near a triangular Lagrangian point, and for Earth, these are near 60° from the Sun in the sky. Yet 2010 TK₇ was discovered near 90° from the

2010 TK₇ 1600-2200

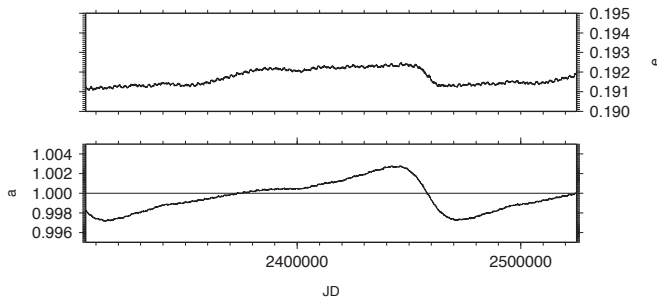

Figure 8 — Orbital parameter survey plot for 2010 TK₇. The bottom panel shows a “sawtooth” pattern of semimajor axis (a) variation, and the top panel the eccentricity e . Labelling as in Figure. 7. An indicator of resonance in Fig. 7 and here is the variation of a around 1.0 AU (horizontal line).

Sun, as dictated by the viewing geometry of the *WISE* survey satellite. After discovery, it quickly moved in to about 45° from the Sun. It spends very little time where Trojans are on average most likely to be seen (Wiegert *et al.*, 2000). Earth’s Lagrangian points are very close to 1 AU away, but 2010 TK₇ near the present time never is that distant. Due to the current motion on its epicycle, and that epicycle being near Earth in the longer-term libration, 2010 TK₇ is not even near the Lagrangian point. How, then, can one know if it really is a Trojan?

Confirmation of Earth Trojan Nature

Orbits cannot be determined exactly. The last observations prior to the discovery of the likely Trojan nature of 2010 TK₇ were on 2010 October 31, and there were a total of 31 observations, including those of *WISE*. As of mid-November 2010, the best-determined value of a , the all-important value of the semimajor axis, was 1.00096 AU, with an uncertainty of 0.003708 AU. This may appear to be a small uncertainty, but the half-width of the resonant region for Earth is only 0.01 AU (Connors *et al.*, 2002). Since the uncertainty was nearly half the width of the resonant region, it could not be concluded with great certainty that the object was in fact an Earth Trojan. Creating “dynamical clones” by varying one or all of the orbital parameters, and performing numerical integration, gives an idea of the types of motion possible within the uncertainty range. Seven clones were created by keeping the other orbital parameters constant and varying a from 0.997 to 1.003 AU in steps of 0.001 AU. Integrations were performed with the Mercury integrator (Chambers 1999) and the results are shown in Figure 11. Carefully following the traces of a shows that three of the seven clones were Trojans, two were horseshoes, and the two at the extrema of the range, marginal horseshoes. At the time of recognition of possible Trojan properties, there was less than a 50-percent chance that the properties of the best nominal orbit were the properties of the real object. More observations were needed.

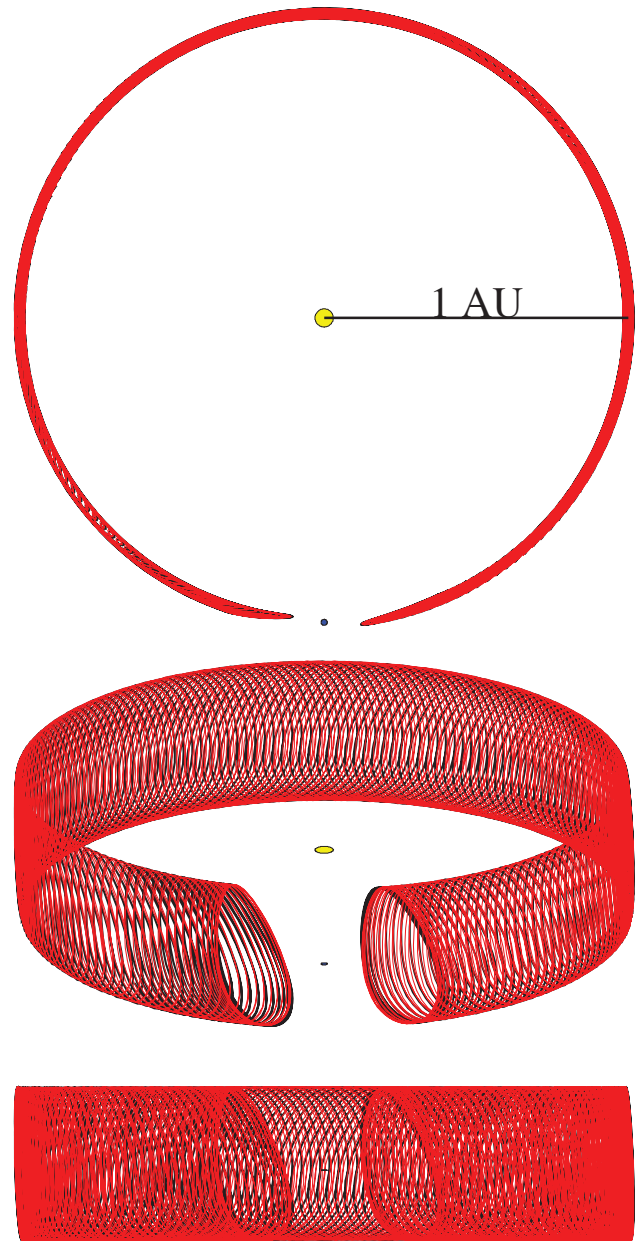

Figure 9 — Co-rotating frame visualization plot for 2010 SO₁₆. The path relative to Earth (blue dot) as it and the asteroid orbit the Sun (yellow dot) is shown from three perspectives: bottom, looking in along the ecliptic plane past Earth toward the Sun; middle, looking over Earth from 30° above the ecliptic plane; top, looking down from the north ecliptic pole. This is a classic horseshoe orbit for an object of low eccentricity and inclination.

Problematically, 2010 TK₇ was already at far-southern declination, limiting the number of telescopes available to observe it. It was dimming rapidly. Even worse, it was rapidly moving toward the Sun in the sky. It would not be observed again until an unconfirmed possible detection in early April 2011, and only on 2011 April 28 was it possible to certainly recover the object (Minor Planet Center 2011), using advanced tracking



Figure 10 — Co-rotating frame visualization plot for 2010 TK₇. Views as in Figure 9. In this survey plot, angles are reversed compared to Figure 2. The period 1800-2000, or half a libration period, is shown, the initial half of this period in red.

techniques on the Canada-France-Hawaii Telescope. At that time, it was approximately of 23rd magnitude. Largely due to the now much-longer observational arc, the error in a was reduced to 2.555×10^{-5} AU. This made it virtually certain that the object was an Earth Trojan associated with the L₄ Lagrangian point, and allowed other unusual characteristics of the orbit to be discussed (Connors *et al.*, 2011). Among these was the possibility to orbit the L₃ Lagrange point unstably, a behaviour first shown as possible by Moulton (1920; p. 173).

2010 TK₇, 1600-2200

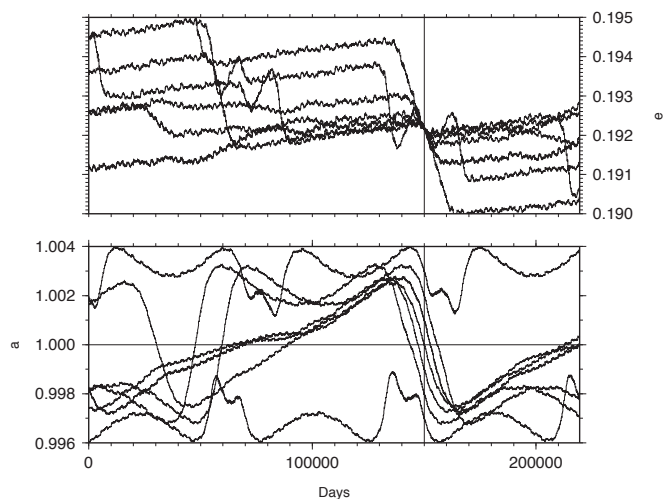

Figure 11 — Orbital parameter plot for clones of 2010 TK₇. The time is labelled in days starting in AD January 1600, until 2200. The date of discovery is marked by a vertical line, and various values of the semimajor axis (bottom plot) are equally spaced on that day. They may be traced from that point to see the type of orbital motion (see text). The values of eccentricity e in the top panel are all the same on the day of discovery, since the clones were generated by varying only the semimajor axis a .

The asteroid can “jump” or transition to libration about the L₅ Lagrangian point from there, in an apparently chaotic manner.

Discussion

To give context to the modern study of Trojan asteroids, we have attempted to lay out the history of celestial mechanics from a time when it was purely descriptive, up to the present age. An intervening period with a geometric and mechanistic view has given way to an era of dynamical complexity that may be studied with capable instruments, advanced computing, and developing theories of complexity and chaos (Ito & Tanikawa 2007). The first Trojan asteroid was discovered possibly in ignorance of the elegant theory of Lagrange that predicted it, which in any case that *géomètre* regarded as a purely mathematical exercise. The modern seeker of new types of behaviour in celestial mechanics has a powerful and generalizable set of tools available to guide the quest. Even so, there are new surprises around every corner.

The basic conclusions about the interesting behaviour of 2010 TK₇ found by Connors *et al.* (2011) were extended by Dvorak *et al.* (2012). They considered the zones of stability possible for Earth Trojans to indicate that, although 2010 TK₇ is an unstable temporary Trojan, there is every reason to expect others to exist. Schwartz and Dvorak (2012) examined mechanisms for temporary captures of Trojans such as 2010 TK₇ by planets, finding them more efficient in the inner Solar System than in the outer Solar System.

An intriguing possibility is that 2010 TK₇ is simply the “tip of the iceberg” and that other objects are deep in the Trojan zones of Earth, yet very difficult to observe. This first Earth Trojan is on an extreme orbit: this was required to even be discovered by *WISE*, which observed only at 90° from the Sun, 30° farther out than where ideal Lagrangian-point Trojans would be. If they exist, very long-lived Earth Trojans might hold material from the Earth zone of the early Solar System. Putative Earth Trojans would be relatively easy to reach with spacecraft. Stacey and Connors (2009) examined what would be required for such a mission. Although certain types of near-Earth asteroids have lower energy requirements, low-inclination Earth Trojans, if found, could still be very attractive targets. With a high inclination of nearly 21°, 2010 TK₇ itself is unlikely ever to be a rendezvous target, but spacecraft have already been to the Earth Lagrangian points several times. The *STEREO* twin spacecraft are in solar orbit to study the Sun, its outer atmosphere, and the heliosphere. By complex orbit manoeuvres involving Earth’s Moon (Kaiser, 2005), they were made to orbit in opposite directions and change position by about 22° per year, thus having initially reached both triangular Lagrangian points about three years after launch on 2006 October 25.

The field of study opened by Lagrange and Wolf is now a very active and interesting one. The discovery of Earth’s exotic Trojan companion holds promise that yet more surprises lurk even in our small corner of the Solar System.

Acknowledgements

Historical research has been facilitated by the large online holdings of the SAO/NASA Astrophysics Data System (<http://adsabs.harvard.edu>). M.C. enjoyed the hospitality of the University of Heidelberg Library and J. Schubart when doing archival research. This and work on asteroid orbits were supported by a Research Incentive Grant from Athabasca University in association with a Canada Research Chair. The Web and “Horizons” services of NASA/JPL were used

(including in generating Figures 5 and 7 through 9), and the NEODYSS site of the University of Pisa also aided in studying asteroid orbits. This publication makes use of data products from the Wide-field Infrared Survey Explorer, which is a joint project of the University of California, Los Angeles, and the Jet Propulsion Laboratory/California Institute of Technology, funded by the U.S. National Aeronautics and Space Administration. This publication also makes use of data products from NEOWISE, which is a project of the Jet Propulsion Laboratory/California Institute of Technology, funded by the U.S. National Aeronautics and Space Administration. This article is based on a presentation made at the 2012 RASC General Assembly.

Endnotes

- 1 Note that in the modern era some comets are known that might be associated with Jupiter’s Lagrangian points: see Jewitt *et al.* (2007)

References

- Brown, E.W. (1911). On a New Family of Periodic Orbits in the Problem of Three Bodies. *MNRAS*, 71, 438-454.
- Chambers, J.E. (1999). A Hybrid Symplectic Integrator that Permits Close Encounters between Massive Bodies. *MNRAS*, 304, 793-799.
- Charlier, C.L. (1906). Über den Planeten 1906 TG. *AN*, 171, 213.
- Charlier, C.L. (1902). *Die Mechanik des Himmels, Erster Band*. Leipzig: von Veit & Comp.
- Charlier, C.L. (1907). *Die Mechanik des Himmels, Zweiter Band*. Leipzig: von Veit & Comp.
- Christou, A.A. & Asher, D.J. (2011). A long-lived horseshoe companion to the Earth. *MNRAS*, 414, 2965-2969.
- Christou, A.A. & Wiegert, P. (2012). A population of Main Belt Asteroids co-orbiting with Ceres and Vesta. *Icarus*, 217, 27-42.
- Connors, M., Veillet, C., Wiegert, P., Innanen, K., & Mikkola, S. (2000). Initial Results of a Survey of Earth’s L4 Point for Possible Earth Trojan Asteroids. *BAAS* 32, 1019-1019.



RASC Internet Resources

www.rasc.ca
Visit the RASC Web site

www.rasc.ca/discussion
Email Discussion Groups

www.rasc.ca/contact
Contact the National Office

www.rasc.ca/news
RASCeNews



Like us on facebook



Follow us on Twitter @rasc

- Connors, M., Chodas, P., Mikkola, S., Wiegert, P., Veillet, C., & Innanen, K. (2002). Discovery of an Asteroid and Quasi-Satellite in an Earth-Like Horseshoe Orbit. *MAPS*, 37, 1435-1441.
- Connors, M., Veillet, C., Brasser, R., Wiegert, P., Chodas, P.W., Mikkola, S., & Innanen, K. (2004). Discovery of Earth's Quasi-satellite. *MAPS*, 39, 1251-1255.
- Connors, M., Wiegert, P., & Veillet, C. (2011). Earth's Trojan Asteroid. *Nature* 475, 481-483, doi:10.1038/nature10233.
- Cunningham, C.J., Marsden, B., & Orchiston, W. (2009). How the first dwarf planet became the asteroid Ceres. *JAHH*, 12, 240 – 248.
- Cunningham, C.J., Marsden, B., & Orchiston, W. (2011). Giuseppe Piazzi: The Controversial Discovery and Loss of Ceres in 1801. *JHA*, 42, 283.
- Cunningham, C.J., & Orchiston, W. (2011). Who Invented the Word Asteroid: William Herschel or Stephen Weston? *JAHH*, 14, 230-234.
- Dvorak, R., Lhotka, C., & Zhou, L. (2012). The orbit of 2010 TK7: possible regions of stability for other Earth Trojan asteroids. *A&A*, 541, A127, DOI:10.1051/0004-6361/201118374.
- Freiesleben, H.C. (1962). *Max Wolf - Der Bahnbrecher der Himmelsphotographie 1863-1932*, Stuttgart: Wissenschaftliche Verlagsgesellschaft.
- Giorgini, J.D. *et al.* (1996). JPL's online solar system data service. *BAAS*, 28, 1158.
- Greene, B. (1999). *The Elegant Universe*. New York: Vintage.
- Gribbin, J. (2002). *Science: A History 1543-2001*. London: BCA.
- Hills, E.H. (1914). *Address*, *MNRAS*, 74, 377-390.
- Holden, E.S. (1896). The Photography of Planetoids, by Professor Max Wolf. *PA*, 3, 343-345.
- Innanen, K. (1991). The Prediction and Discovery of a Martian Trojan Asteroid. *JRASC*, 85, 151-157.
- Ito, T. & Tanikawa, K. (2007). Trends in 20th Century Celestial Mechanics. *PNAOJ*, 9, 55-112.
- Jewitt, D.C., Sheppard, S., & Porco, C. (2007). Jupiter's Outer Satellites and Trojans. In F. Bagenal, T.E. Dowling, & W. McKinnon (Eds.), *Jupiter: The Planet, Satellites, and Magnetosphere*, (pp. 263-280). Cambridge, UK: Cambridge.
- K.L. (unnamed contributor) (1935). Karl Vilhelm Lugvig Charlier. *MNRAS*, 95, 339-342.
- Kaiser, M.L. (2005). The STEREO mission: an overview. *AdSpR.*, 36, 1483-1488.
- Kopff, A. (1928). Max Wolf und die Entwicklung der modernen Astronomie. *NW*, 16, 501-503.
- Kuhn, T.S. (1957). *The Copernican Revolution: Planetary Astronomy in the Development of Western Thought*. Cambridge, MA: Harvard.
- Lagrange, J.-L. (1772). Essai sur le problème des trois corps, Prix de l'Académie Royale des Sciences de Paris, IX; reprinted in Lagrange, J.-L. (1867-1892). In J. A. Serret & G. Darboux (Eds.), *Oeuvres de Lagrange, Tome 6* (pp. 229-334). Paris: Gauthier-Villars; available at <http://gallica.bnf.fr/ark:/12148/bpt6k229225j/f231>, cited 2012 May 1.
- Lecar, M., Franklin, F.A., Holman, M.J., & Murray, N.W. (2001). Chaos in the Solar System. *ARA&A*, 39, 581-631.
- Mainzer, A. *et al.* (2011a). Preliminary Results from NEOWISE: An Enhancement to the Wide-Field Infrared Survey Explorer for Solar System Science. *ApJ*, 731, 53(13pp), doi: 10.1088/0004-637X/731/1/53.
- Mainzer, A. *et al.* (2011b). NEOWISE Observations of Near-Earth Objects: Preliminary Results. *ApJ*, 743, 156(17pp), doi: 10.1088/0004-637X/743/2/156.
- Mainzer A. *et al.* (2012). Physical Parameters of Asteroids Estimated from the WISE 3 Band Data and NEOWISE Post-Cryogenic Survey. *ApJ Lett.*, 760, L12(6pp), doi: 10.1088/2041-8205/760/1/L12.
- Masiero, J.R. *et al.* (2012). Preliminary Analysis of WISE/NEOWISE 3-Band Cryogenic and Post-cryogenic Observations of Main Belt Asteroids. *ApJ Lett.*, 759, L8(5pp), doi: 10.1088/2041-8205/759/1/L8.
- Minor Planet Center (2010). MPEC 2010-T45: 2010 TK7, <http://www.minorplanetcenter.org/mpec/K10/K10T45.html>, cited 2013 November 12.



SERVING AMATEUR ASTRONOMERS FOR OVER 22 YEARS!

toll-free 1-800-580-7160
info@khanscope.com

www.khanscope.com

All Major Brands of Telescopes including:
 Meade | Celestron | TeleVue | Coronado | APM
 SkyWatcher | William Optics | Rigel | Baader
 Nikon | Antares | Telrad | Denkmeier | Equinox
 Thousand Oaks | Kendrick | Lunt Solarsystems
 TeleGizmos | Ioptron | Sky Pub & Others

NEW | USED | TRADE-INS
WE SHIP CANADA WIDE

KHAN SCOPE CENTRE

3243 Dufferin Street, Toronto, ON M6A 2T2
 Phone: 416 783 4140 | Fax: 416 352 1701

- Minor Planet Center (2011). MPEC 2010-T60: 2010 TK7, <http://www.minorplanetcenter.net/mpec/K11/K11O60.html>, cited 2013 November 13.
- Moulton, F.R. (1920). *Periodic Orbits*, Washington: Carnegie Institution.
- Moulton, F.R. (1914). *An Introduction to Celestial Mechanics*, 2nd Ed. New York: MacMillan.
- Petersen, I. (1993). *Newton's Clock: Chaos in the Solar System*. New York: Freeman.
- Schwartz R., & Dvorak, R. (2012). Trojan capture by terrestrial planets. *CeMDA*, 113, 23-34, DOI 10.1007/s10569-012-9404-4.
- Stacey R.G., & Connors, M. (2009). Delta-v Requirements for Earth Co-orbital Rendezvous Missions. *P&SS*, 57, 822-829, doi: 10.1016/j.pss.2009.01.013.
- Stuart J.S., & Binzel, R.P. (2004). Bias-corrected population, size distribution, and impact hazard for the near-Earth objects. *Icarus*, 170, 295-311.
- Whitley R.J., & Tholen, D.J. (1998). A CCD Search for Lagrangian Asteroids of the Earth-Sun System. *Icarus*, 136, 154-167.
- Wiegert, P., Innanen, K.A., & Mikkola, S. (2000). Earth Trojan Asteroids: A Study in Support of Observational Searches. *Icarus*, 145, 33-43.
- Wiegert, P., Innanen, K.A., & Mikkola, S. (1997). An asteroidal companion to the Earth. *Nature*, 387, 685-686.
- Wilson, C. (1995). The work of Lagrange in celestial mechanics. In R. Taton, & C. Wilson (Eds.), *Planetary Astronomy from the Renaissance to the rise of astrophysics: Part B: The eighteenth and nineteenth centuries* (pp. 108-130). New York: Cambridge
- Wisdom, J. (1987) Urey Prize Lecture: Chaotic Dynamics in the Solar System. *Icarus*, 72, 241-275.
- Wolf, M. (1906a). Photographische Aufnahmen von kleinen Planeten. *AN*, 170, 321.
- Wolf, M. (1906b). Photographische Aufnahmen von kleinen Planeten. *AN*, 172, 387.
- Wolf, M. (1907). Photographische Aufnahmen von kleinen Planeten. *AN*, 174, 63.
- Wolf, M., & Kopff, A. (1907), Benennung von kleinen Planeten. *AN*, 175, 191.
- Wright, E.L. *et al.* (2010). The Wide-field Infrared Survey Explorer (WISE): Mission Description and Initial On-Orbit Performance. *AJ*, 140, 1868-1881.



SkyShed POD MAX

Now completing development
and launching shortly!

- Rugged construction (Built like a tank) 5.5" thick walls
- 6' 4" high wall with 32" wide door and a deadbolt lock
- Most affordable medium-sized dome ever
- Easy to assemble
- Multi configurations with POD MAX Bays and Dome only option
- Manual control to remote control
- Electronics by Kendrick Astro Instruments
- Designed for astro photography, education, and research
- Perfect for schools, clubs, and individuals with large scopes
- Ships to your door
- Prices estimated at 4K – 10K depending on model and level of automation
- 12.5' dome with traditional slot design, 44" wide opening
- 20 degrees past zenith view



**Made in Canada for
world wide export**

For more information please visit:

www.skyshedpodmax.com

Canada and the 1833 Leonids

by Clark Muir,

Kitchener-Waterloo Centre (cmuir10@rogers.com)

*so much admiration and delight by one class of spectators,
or with so much astonishment and fear by another class.*

– Denison Olmsted on the meteor shower from
the United States

Abstract

The 1833 Leonid meteor shower was widely viewed over the eastern half of North America and the western portions of the North Atlantic Ocean. Despite the abundance of references, there is very little of record in popular works detailing the Canadian experience. Many accounts indicate that the meteor storm was witnessed throughout eastern Canada, but aside from one specific instance, virtually no other locations or names of witnesses are given. In this article, a brief description of the meteor shower is presented, followed by a more-detailed look at the people who witnessed the event from Canada, the places from where they observed, and their personal stories. These uniquely Canadian accounts are just as vivid and memorable as the reports from other parts of the continent.

Introduction

The event, in the early morning of 1833 November 13, would not be forgotten by anyone who witnessed it. Few people would have been awake in those predawn hours, but those who were could not have missed the spectacle in the sky. For the most part, their instinctive reaction upon seeing the “falling stars” was to immediately alert loved ones, neighbours, and nearby friends, though in some cases, witnesses were hesitant to sound the alert for fear the phenomenon would cease before they got one last look. Other observers would have been drawn outside by the commotion raised as people gasped at what they were seeing.

As expected, eyewitnesses differ greatly on some of the details. Among the most obvious discrepancy was the rate of fall of the meteors. It would be impossible for most individuals to properly give an accurate number, so estimates ranging from a few at any one moment to “millions” were given. Other details, like the duration, time, direction, and brightness, are also somewhat inconsistent.

Fortunately, many reports are preserved in a well-known paper written by Denison Olmsted (1791-1859) in 1834. Olmsted’s work documents many observations from an assortment of American cities and locations, from the east coast to as far west as Missouri; there are even eyewitness reports from ships in the Atlantic Ocean and the Gulf of Mexico. Olmsted’s sizable collection is probably the single largest source of observations, yet it contains nothing from Canada.

The Storm

Probably no celestial phenomenon has occurred in this country, since its first settlement, which was vivid with

The most dramatic scenes offered by the meteor shower or “storm” occurred during the dark hours before the break of dawn, long after the three-day-old Moon had settled below the horizon. Beyond the remarkable rate of the meteors, there were a few other widely reported phenomena. The brighter meteors were often seen leaving a trail of “sparks” or “sky rockets.” Many observers reported seeing incredibly bright bolides, in a few instances, compared to the brightness of planets or the full Moon. On rare occasions, they were accompanied with sound. In a few places, Buffalo, New York, being one, a faint aurora was noticed during the meteor shower. In 1833, there was a notion that the aurora and meteors may be related.

The meteors’ rate of fall was very difficult to calculate accurately and varied depending on the observer’s location on the continent. A number often given as a starting point is 30,000 per hour, but other estimates go much higher. A rate of 100,000 per hour would be astounding, translating to about 30 per second. Since many witnesses typically described the stars “falling like rain” (another common analogy), a rate of 30 per second across the entire sky seems plausible. Considering that most observers would have seen only one portion of the sky at any one moment, the rate may well be higher. Corrections to the rate to compensate for cloud cover are probably not necessary as the detection of meteors was greatly aided by the weather conditions, with many areas described as having an unusually clear and transparent sky.

Certain clichés turn up often to describe the event: adjectives like “splendid,” “spectacular,” and “phenomenal” are used recurrently. Descriptive phrases such as “flakes of snow” or “shower of fire” also show up repeatedly.

Some attentive observers could not only determine the constellation from where the meteors appeared to come, but could pinpoint the exact spot of the radiant. One witness placed the radiant at a point slightly north and west of Gamma Leonis (a beautiful double star in the sickle of Leo). That imaginary spot within Leo remained the radiant point for the hour or two that the meteors were visible as the constellation continued to rise.

The View from Canada

Following is a list of descriptions that originate from Canada. They include locations and, when known, the names of individuals from Canadian sources of the 1833 Leonid meteor shower. For the most part they are found in newspapers from the time or were preserved in personal diaries.

Niagara Falls, Ontario

There are many illustrations that depict the astonishing event. Some show people on their knees with arms extended upwards. Others show entire towns gazing at the sky. All show the sky streaming with countless meteors usually streaking away from the radiant.

One of the more striking portrayals of the storm comes from a famous woodcut (Figure 1) of the shower as seen from Niagara Falls, a location instantly recognizable by anyone familiar with the waterfalls, though the viewing point in the image is from the American side. In any case, Niagara Falls is clearly one Canadian location that had an excellent view of the meteors.

Douro, Ontario (north of Peterborough): Col. Samuel Strickland and Catherine Parr Traill

Perhaps the most detailed record of the event from Canada comes from Colonel Samuel Strickland (1806-1867), who provided one of the very few Canadian references that have been widely published. Strickland was mentioned in a page or two in *Heavens on Fire: The Great Leonid Meteor Storm*, written by Mark Littmann. Littmann gives Strickland's location for viewing the Leonids rather vaguely as Canada West (Ontario).

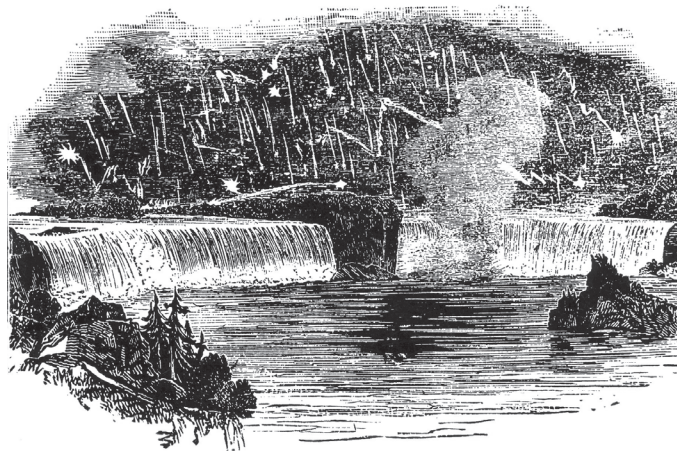

Figure 1 — An 1833 woodcut showing the meteor shower, viewed from Niagara Falls. Image: RASC.

Strickland is well known as an early pioneer who settled in the region in the 1820s. He was a well-educated man who kept excellent records of his day-to-day life in the Canadian wilderness, writing about his experiences in his book *Twenty Seven Years in Canada West*, which likely gave Littmann the geographical reference he used for Strickland's observation. Two of Strickland's sisters, Catharine Parr Traill (1802-1899) and Susanna Moodie (1803-1885), also made the difficult journey from England and arrived in Upper Canada in 1832. Both women were authors in England, and both also wrote about their experiences in Canada. Today their journals,

sketches, and books are admired for preserving the personal experiences of women settling in the new wilderness.

Strickland was joined by his sister Catharine in the autumn of 1833. Their two families had to struggle to farm land on adjoining acreages on lakefront property (perhaps on Lake Katchewanooka) not far from Lakefield, Ontario. It was here that the siblings and members of their families witnessed the 1833 meteor storm.

An excerpt from Strickland's book from Chapter 13 titled "Falling Stars" gives us his description:

I think it was on the 14th of November, 1833, [actually the 13th of November] that I witnessed one of the most splendid spectacles in the world. My wife [Mary] awoke me between two and three o'clock in the morning, to tell me that it lightened incessantly. I immediately arose and looked out of the window, when I was perfectly dazzled by a brilliant display of falling stars. As this extraordinary phenomenon did not disappear, we dressed ourselves and went to the door, where we continued to watch the beautiful shower of fire until daylight.

These luminous bodies became visible in the zenith, taking the north-east in their descent. Few of them appeared to be less in size than a star of first magnitude; very many of them seemed larger than Venus. Two of them, in particular, appeared half as large as the moon. I should think, without exaggeration, that several hundreds of these beautiful stars were visible at the same time, all falling in the same direction, and leaving in their wake a long stream of fire. The appearance continued without intermission from the time I got up until after sunrise. No description of mine can give an adequate idea of the magnificence of the scene, which I would not willingly have missed.

This remarkable phenomenon occurred on a clear and frosty night, when the ground was covered with about an inch of snow...

Immediately after his description of the meteor shower, a poem "The Shooting Star" by another sister, Agnes Strickland (1896-1874), was printed in the chapter in his book. Although Agnes Strickland did not come to Canada, Strickland felt compelled to include her poem.

In her diary *The Backwoods of Canada*, Catherine Parr Traill gives us her much briefer account of the meteor shower and includes an interesting analogy provided by a young farm worker.

Traill writes:

I have seen the aurora borealis several times; also a splendid meteoric phenomenon that surpassed everything I had ever seen or even heard before. I was very much amused by overhearing a young lad giving a gentleman a description of the appearance made by a cluster of the shooting stars as they

followed each other in quick succession athwart the sky. "Sir" said the boy, "I never saw such a sight before, and I can only liken the chain of stars to a logging-chain." Certainly a most natural and unique simile, quite in character with the occupation of the young lad, whose business was often with the oxen and logging-chain, and after all not more rustic than the familiar names given to many of our most superb constellations,—Charles's wain, the plough, the sickle etc.

Author Sara Eaton (1928-2010) offers a little more insight into Traill's account in her book about Traill's life, *Lady of the Backwoods*:

On November 14 [actually November 13], a clear night, Mary, who had been up with the baby [Strickland and Traill and their spouses] stood until nearly dawn, dazzled by the most brilliant display of falling stars they had ever seen. Few of the stars were of less than first magnitude. Many were as large as Venus, and two at least half as big as the Moon.

Strickland and Traill are commemorated by plaques issued by the province of Ontario for their contribution to the settlement of the area. Strickland's plaque can be found near a church in the town of Lakefield, Ontario, where he is buried. Nearby, at Youngs Point, a plaque highlights Traill's life. Both Traill and Moodie are also featured in a collector's stamp printed by Canada Post showcasing outstanding Canadian authors.

Although Susanna Moodie was in Upper Canada in 1833, there appears to be no record of the meteor shower in any of her writings.

Toronto, Ontario

Just four months after the Leonids put on their display, on 1834 March 6, the town of York became the city of Toronto.

Rev. C. Dade M.A. witnessed the spectacle in or near York.

In concluding this subject we may observe, that this year was of itself not only remarkable for electric phenomena, [refers to severe thunderstorms in 1833 or 1834] but was likewise ushered in by one of the most remarkable ever witnessed. I allude to the meteors of November, 1833. The weather previous had been mild and showery, and on the night of the 12th, and nearly to the dawn of day, the sky was illumined with millions of meteors, darting from the zenith to the horizon like sky-rockets, thick as the flakes of a snow-storm. In one instance a meteor exploded with considerable noise, leaving behind it a brilliant train of light which lasted some minutes.

Dade's personal account is included in an article discussing the cholera seasons of 1832 and 1834 in Toronto. Dade's report is one of the few from Canada that attributes sound to a bright bolide.

Another Toronto source is given in an anonymous letter to a local newspaper. An eyewitness noted that it started at 4 o'clock and continued to daylight and goes on with the theme that it was the most "splendid exhibition of meteoric lights ever seen." There is also a note that the meteors were seen "by several inhabitants of this town (York) and adjoining country."

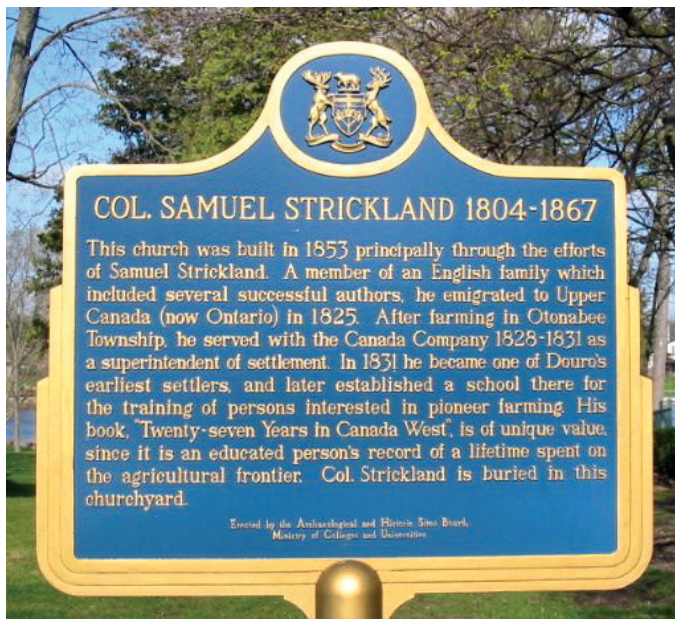

Figure 2 — An Ontario provincial plaque commemorates the contribution of Col. Samuel Strickland in Lakefield, Ontario. Strickland witnessed the 1833 meteor shower from his farm with his spouse in nearby Douro, Ontario. (Courtesy ontarioplaques.com); An Ontario provincial plaque commemorates Catharine Parr Traill. Traill is the sister of Strickland, who, with her husband, witnessed the 1833 meteor storm from Douro, Ontario. (Courtesy ontarioplaques.com)

Later in the letter, another significant observation is made concerning the overall brightness of the meteors: “There was cast through the atmosphere a universal light which was observed by persons awake at the time to penetrate their chamber windows so vividly, as to call them from their beds to inquire the cause.” This is an exceptional declaration. I do not know of any other records that suggest people had noticed the meteors strictly by their accumulative light entering their dwellings. It is worth pointing out that, in modern times with the encroachment of light pollution within our cities and towns, this experience would likely not be possible.

Further in the letter, the anonymous writer captures with dramatic flair the thoughts and actions of other individuals from the delighted to the fearful:

Several of those persons, who had the pleasure of enjoying the magnificent sight, describe their feelings as accompanied with anxious desire of calling their friends to partake of their wonder, yet feared to quit, lest all might vanish while they turned their eyes from the scene. Still the meteors shot their way and fell, and melted in prodigious profusion till day-light, when the brighter glories of the approaching Sun, extinguished the scene, were variously effected: Some with agreeable delight—others with apprehensions of evil, but all with astonishment. Some gave character to their feelings by exclaiming “the sky is falling to pieces!” others that “the stars were dancing.

And finally, in the conclusion there is an attempt made to encourage other eyewitnesses who presumably must have seen the event from surrounding areas to come forward and tell their story.

As far as can be at present ascertained, as to the extent of this phenomenon, it seems to have been visible from Whitby, about thirty miles eastward of York, over York and northerly and westerly from them—how far to the north and east has not yet been learned. It is hoped that the newspapers of the adjoining districts will inform the public of its appearance & apparent extent in their respective neighborhoods. So singular a display of nature’s wonders ought to be recorded.

If the writer’s assessment is correct that it was visible in the surrounding areas, there is reason for considerable optimism that other accounts may be found.

Cobourg, Ontario

The 1833 diary of George Pashley catalogues his voyage from Liverpool, England, to Upper Canada and his life in Cobourg (on Lake Ontario between Toronto and Kingston). The document is relatively short but tells a tale of insufferable hardship. Pashley’s youngest daughter Eliza died at sea during the voyage to Canada, while fellow passengers lived in squalid

conditions. Among these particulars are some small acts of kindness and empathy from others who would have been complete strangers to Pashley and his family.

Despite these more imperative details, Pashley had included the meteor shower in his notes. Although he did not witness the Leonids from his home near Cobourg, he heard about it from others, presumably by word of mouth, the very next morning. Pashley also mentioned that accounts were recorded in many newspapers.

Kingston, Ontario

In a letter to the editor, this time in a Kingston paper, there is another anonymous writer who did not witness the event but heard from many that did. “I have had accounts of it from so many and various quarters that I cannot question the accuracy of the facts stated...” Curiously, he writes that he was surprised at the lack of coverage in papers on the meteor shower. Beyond the usual descriptions, this time starting at about 2 a.m., the writer insists it was seen “as far up the Bay of Quinte as Adolphustown.”

Windsor, Ontario

In Windsor, Ontario, at least one newspaper included details about the meteor shower that appeared to come from eyewitnesses from other jurisdictions: a notice from the *Detroit Courier* stated that the meteors were seen in Detroit, Buffalo, and Albany, *etc.* This is an indication that in the Windsor area, and probably the Lake Erie shore of Ontario, there were ideal conditions for observing the Leonid shower.

Province of Québec

Several newspapers in Québec reported on the meteors, but most accounts originated from the United States. One exception was an article that included a crude sketch of the meteor storm from a New York source showing streams coming from a radiant in the sky. The article went on to mention local sightings. Although no details are given, it indicated that residents of Vaudreuil, Rigaud, and L’Île Perrot (towns south and west of Montréal, described as Montréal district parishes) witnessed the meteors on the same day and time as the other reports. A brief article in another newspaper from Québec City confirms that, from these Québec locations, the meteors; “resembled a shower of fire so vivid that it rendered the heavens almost as light as day.”

The lack of other local reports indicates it may be that many populated parts of Québec had cloudy conditions during the evening and early morning hours of 1833 November 12 and 13.

continues on page 72

Pen & Pixel

Figure 1 — The unusual galaxy M82 is much in the news these days because of the discovery of a new Type 1a supernova. This image from Eric Benson shows the dynamic structure of the galaxy, with tendrils of hydrogen gas erupting from the core. M82 lies at a distance of 12.5 Mly in Ursa Major and shares the sky with nearby M81. Eric used a C14 XLT telescope at $f/6.1$ with an SBIG ST8XME camera. Exposure was $8 \times 600s$ in each of RGB and $12 \times 1800s$ in H α .



Figure 2 — Steve McKinney of the Toronto Centre sent the Journal this image of the Cocoon Nebula, taken on July 29 last year. The Cocoon is a beautiful red emission nebula in Cygnus set within a halo of blue reflection nebosity. This image was acquired using a Takahashi TSA-102 telescope and an SBIG ST8300M camera. Exposures were $8 \times 900s$ in L, $8 \times 600s$ in R, and $9 \times 600s$ in G for a total of 4.8 hours.



Figure 3 — Tom Zaranek and Paul Mortfield combined efforts to acquire and process this image of M63 (the Sunflower Galaxy). This relatively bright galaxy (magnitude 9.6) lies at a distance of 46 Mly in Canes Venatici. Many star-forming regions, glowing in pinkish hues, are visible in the spiral arms. LRGB exposures were 210:60:60:60 minutes for a total of 6.5 hours using a 16" f/8.9 RCOS telescope and an Apogee U16M camera.



Figure 4 — London Centre's Richard Henderson sends us this image of a favourite winter target—the galaxy M33 in Triangulum, taken from his backyard observatory in Chatham, Ontario. M33 is a low-surface-brightness galaxy, best seen visually with low magnification and dark skies, though its integrated magnitude is a bright 5.2. Richard used a TMB 130-mm f/7 refractor and an SBIG 11000M camera. Exposure was a total of 5 hours in RGB plus 1 hour in H α .

Nova Scotia

An image of the meteors falling from a radiant tops the headline in a story from the *Acadian Recorder*, Halifax, Nova Scotia:

METEORS—The New York Commercial Advertiser has a communication on a meteoric shower, seen during the present month; the same doubtless which has been seen in Halifax and other parts of Nova Scotia...

Fortuitously, the above story can be supplemented with a wonderful eyewitness account from *The Yarmouth Herald*, 1833 November 22. It is from an anonymous man who resided on the east side of Halifax harbour. It is presented here in its entirety;

On looking out of the West window of my cottage in Dartmouth this morning I was surprised to observe a number of stars shooting rapidly from the zenith towards the horizon, leaving very brilliant trains of light after them. I immediately went to the southern also to the eastern windows and observed the same appearance, twenty or thirty stars were in motion; consequence of this extraordinary occurrence, I immediately called my family who also observed the same thing, and sat at the windows, for the space of half an hour, admiring. While looking out of the window, the town and harbour became suddenly illuminated, as I thought by lightning, but on running to the south windows we perceived a brilliant meteor had burst to the east of Fort Clarence, leaving a brilliant train of light in the sky which lasted I suppose 20 seconds after we reached the window; at the time we saw the greatest light, we heard an explosion distinctly—the shooting of the stars continued until daylight had so far advanced as to obscure them; a strong breeze to the west was blowing at the same time. Being determined to see as much as possible of this singular phenomena I went out and observed a bright cloud to the N.E. and this surprising shower of stars falling in every direction.

— Halifax Nova Scotian

What a sight! Imagine, Halifax harbour lit up by nothing but meteors at a time when artificial lights were but an occasional oil lamp. This is the only other testimonial cited here that includes sound associated with the meteors in Canada.

One last observation from Halifax comes from *The Halifax Journal* printed in a Québec paper on 1833 December 6:

Shower or Fire—On Wednesday morning almost half an hour before daybreak, the heavens presented the unusual appearance of a “shower of fire”. The atmosphere was perfectly clear and very calm—Many persons rose from their beds with the impressions that a fire was raging in the vicinity of their dwellings. The most singular thing is, that this appearance was observed

Conclusion

Within Canada, the area of the visibility of the meteors was widespread, and there are more records out there waiting to be found. I have found nothing from New Brunswick at all. Newfoundland newspapers described the meteor shower from United States’ reports, suggesting, similar to Québec, that the lack of local accounts indicated that it was not visible from there. Perhaps Newfoundland was too far east and the meteors were lost at the first sight of dawn.

Despite numerous locations within Canada, there are still very few names associated with the meteor shower. Anonymous eyewitnesses and writers played a vital role in telling this story.

It is noteworthy, considering the time of year, that so much of eastern Canada had favourable sky conditions. November, at least in southern Ontario, is notorious for its relentless cloud cover—just ask any amateur astronomer.

It is not surprising that the inconsistencies observed about the rate of fall in the American encounters were also demonstrated in the Canadian reports. The declaration that the sky was “almost as light as day” surely must be an exaggeration. Perhaps a bright bolide or two did light up the sky for a brief moment.

Reports about the time of commencement vary by two or three hours. Also, the point of the radiant varies, as some believed the meteor radiant was at the zenith. (It appears in one case that the witness never even stepped outside his dwelling.) Finally, although reported in the United States on some occasions, there is no reference to the aurora in the Canadian examples. It is most unfortunate that the request for eyewitness reports made by Olmsted did not reach, or was not heeded, in Canada. I suspect that many more reports from Canada would have been preserved had they reached him. As a result, most of the records from Canadians that observed the meteor shower are probably lost.

I continually have to remind myself that these hearty observers from 1833 knew nothing of light pollution. This seems an obvious point, but with no Moon in the sky on that morning, the ability to see the meteors without having to deal with a bright sky caused by electrical lights would have made observations of the spectacle even more widespread. I believe that if a similar exhibition were to happen today, most city dwellers would not even notice. Today, we would likely have some proclamation of an impending brilliant meteor shower, but in this day of fast-paced news cycles, it would likely be lost to all but the keenest of amateurs. Aside from the possible bright bolide or two, nothing else would be perceived. *

References

- Anon. (1833 November 22). Singular Phenomenon. *The Yarmouth Herald*, p. 2.
- Anon. (1833 November 23). Atmospheric Phenomenon. *The Canadian Correspondent*, p. 4.
- Anon. (1833 November 23). Letter to the editor. *Kingston Chronicle and Gazette*, p. 4.
- Anon. (1833 November 30). Meteoric Exhibition. *Canadian Emigrant and Western District Advertiser*, p. 3.
- Anon. (1833 November 30). Meteors. *Acadian Recorder*, p. 3.
- Anon. (1833 November 23). Phenomene Extraordinaire. *L'ami Du Peuple*, p. 3.
- Anon. (1833 November 26). Québec November 26 1833. *The Quebec Mercury*, p. 3.
- Anon. (1833 December 6). Shower or Fire. *The Montreal Vindicator*, p. 2.
- Dade M.A., R.C. (1862). Notes on the Cholera Seasons of 1832 and 1834. *The Canadian Journal of Industry, Science and Art*, 27.
- Eaton, S. (1969). *Lady of the Backwoods*. Toronto: McClelland and Stewart.
- Olmsted, D. (1834). Observations of the Meteors of November 13th 1833. *The American Journal of Science and Arts*, 363-411.
- Pashley, G. (1834). *Journal of George Pashley*.
- Strickland, S. (1853). *Twenty-Seven Years in Canada West; or The Experience of an Early Settler*.
- Traill, C.P. (1836). *The Backwoods of Canada; Being Letters From the Wife of an Emigrant Officer*.

AstroNuts Going Strong

by Ray Bielecki

(ray@astronutskidsspaceclub.com)

The AstroNuts kids' space club, chronicled in the August 2011 *Journal*, continues to gather kudos in the Newmarket, Ontario area. AstroNuts was founded in 2010 by then 7-year-old Brett Bielecki and his father, Ray, as a place where neighbourhood kids could come together to learn about rocketry, astronomy, technology, and "everything space." They have received support from local RASC members, especially Mark Fitkin and Susan Liebman of NEOS (New Eyes Old Skies).

According to Ray Bielecki, "...we meet at our home in Newmarket once a month for a 'mission' which involves fantastic presentations by volunteer 'space educators' who engage the kids in an imaginative and fun way. Our 'centrepiece' is 'Spaceship Mercury Two'—our homemade spaceship made completely out of "space junk."

AstroNuts hosts an annual "What's Up in Space" camp together with the AstroNuts STEM (Science, Technology, Engineering, and Mathematics) contest. The camp brings educators and hundreds of elementary school kids together in a fun atmosphere of presentations and activities. The STEM contest shows off projects created by students that are judged by three scientists, after which the winning projects are presented to the entire camp. ★



Figure 1 — Last December, the AstroNuts entered a Soyuz rocket-ship float into both the daytime Newmarket Santa Claus Parade and the nighttime Aurora Santa under the Stars Parade. They won the Mayor's Trophy and Best Original Theme awards for their efforts!

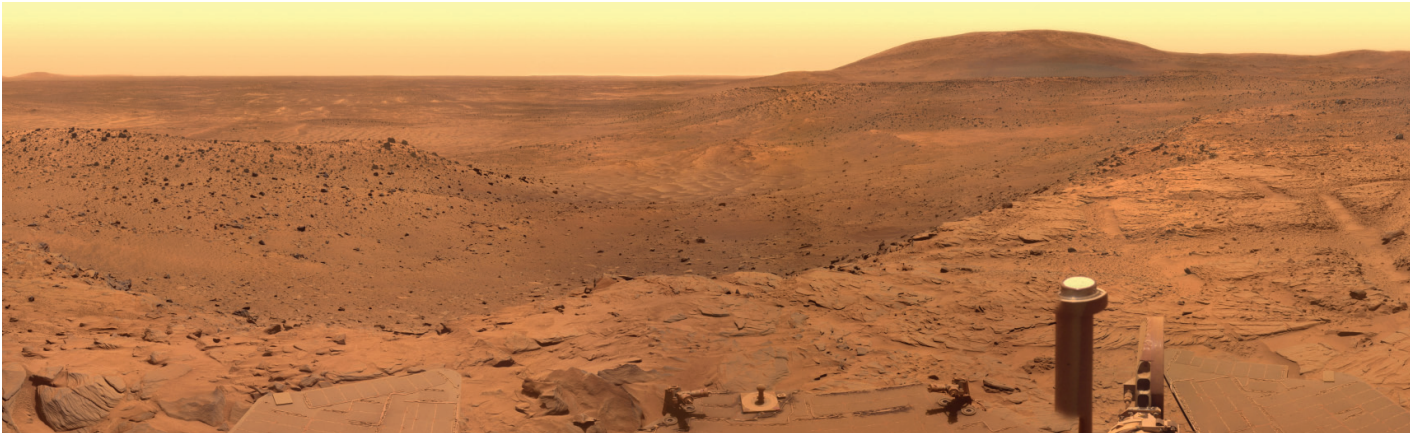

Figure 1 — A panorama of Mars's West Valley captured by the Spirit rover. Features in this image: Tsiolkovski Ridge (hill on the left), Grissom Hill (behind Tsiolkovski Ridge, on the horizon, about 8 kilometres away), and Husband Hill (above Spirit's mast, 800 metres away). Image credit: NASA/JPL/Cornell/James Convin.

Should We Colonize Mars?

by Michael Gainer

Early popular notions of the planet Mars were, for the most part, formed by the observations and speculations of Percival Lowell in the late 19th and early 20th centuries. He posited the existence of an intricate canal system, built by sentient beings of superior intelligence, that had been or were still living there. These ideas were reinforced by H.G. Wells in his book *The War of the Worlds* (1898) and later science-fiction writers. That image had become so common that thousands panicked in 1938, when they listened to the Orson Welles' radio broadcast of *The War of The Worlds*, believing that Martians had invaded Earth.

Although that earlier view has now been dismissed by evidence obtained from photographs and instrumentation on Mars's surface and by orbital surveyors, there is new speculation among non-fiction and science-fiction writers that the planet is somehow habitable, and steps should be taken to colonize it. Let's look at what Mars is really like and what colonists would confront.

Mars is not the bright, sunny place that it appears to be on photos taken by robotic Mars surface explorers. Since it is 1.5 times farther from the Sun than Earth, its cloudless sky is at about the same brightness as an overcast day on Earth. Its diameter is slightly more than one-half of Earth's, resulting in a surface gravity of 0.376 of Earth's. A person weighing 150 pounds on Earth would weigh 56 pounds there.

Its almost non-existent atmosphere produces an atmospheric pressure approximately equivalent to the vacuum you would obtain in a bell jar with a simple mechanical pump, equal to the pressure 13 km above Earth's surface. It consists of 95.3 percent carbon dioxide, 2.7 percent nitrogen, 1.6 percent argon, 0.13 percent oxygen, and 0.08 percent carbon monoxide.

The planet's orbit is highly eccentric. Aphelion is 42,600,000 km greater than perihelion. Currently, Mars is at perihelion when it is summer in its southern hemisphere and at aphelion when it is winter in the southern hemisphere. As a result, the seasons—twice as long as Earth's—are more extreme in the southern hemisphere than in the northern. Its thin atmosphere retains little heat. The temperature at the equator during its warmest days will go from 30 °C during the day to -150 °C at night. Liquid water cannot exist on the planet, because it immediately evaporates at the low atmospheric pressure.

Mars is covered by a layer of iron-oxide dust that gives it its red colour. Because of low surface gravity and a high vertical temperature gradient, fine dust particles can be raised to high altitudes. When weather conditions are right, planet-wide dust storms can develop that obscure most of the surface from space. They occur when Mars is near perihelion and the temperature gradient is most extreme. Storm duration can range from weeks to months. The probability of such a storm in a given year is about 30 percent.

Mars does not have a magnetic field to deflect solar and cosmic radiation. Its thin atmosphere does little to shield it from radiation that would be lethal to colonists.

There are 43,000 known impact craters on Mars that are five kilometres or larger in diameter, mostly formed in its early history. In recent years, several small newly created ones have been discovered by cameras on the *Mars Reconnaissance Orbiter*. Mars's orbit brings it near the inner edge of the asteroid belt. Because of this, and its thin atmosphere, it has had a relatively high impact rate compared to Earth but less than the Moon. It has been estimated that the Martian atmosphere should protect it from impacting meteorites with masses from 10 grams to 1 ton.

Given these conditions, what would have to be done to support a viable colony?

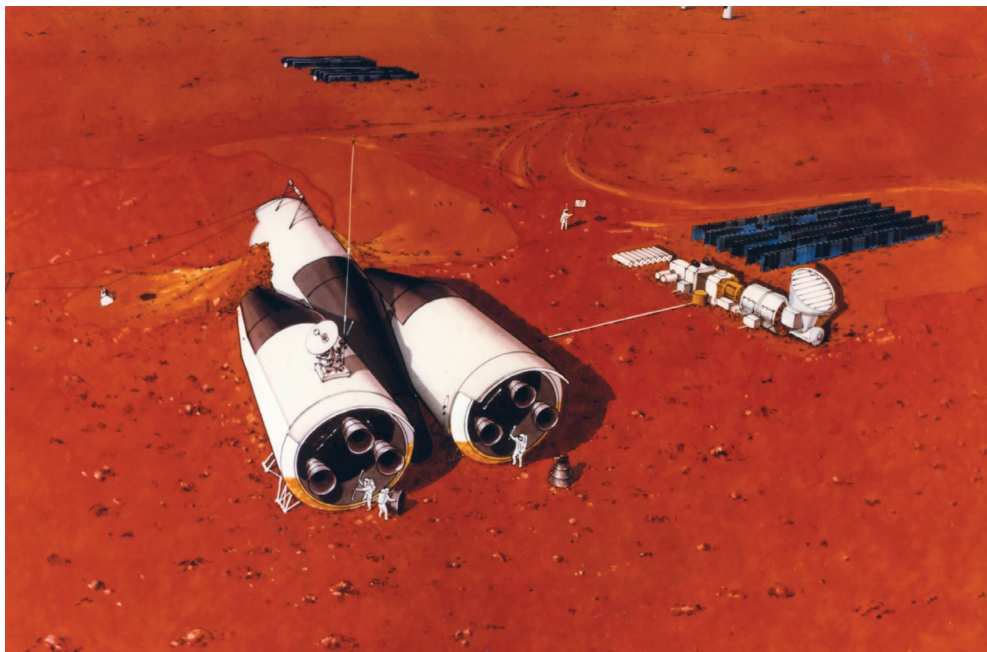

Figure 2 — An artist's concept of a Mars base. In this scene, astronauts use three shuttles covered with "Mars dirt" to begin their Mars colony. This artist conception was provided by CASE FOR MARS, an independent organization concerned with a Mars mission. Source: NASA.

To begin with, we know very little about the effects of low gravity on human physiology. Humans have never spent an extended period in a gravitational field as weak as that on Mars. From the space programs, we have experience with zero gravity and lunar gravity for relatively short periods of time. Colonists on Mars will be in a low-gravity environment for years or even the rest of their lives. How will low gravity affect muscle and bone density, metabolism, and fetal development? Will the combination of low gravity and radiation produce generations of mutants?

All living quarters would be man-made structures in caves or underground limit long-term exposure to cosmic and solar radiation. They would need to be pressurized with a manufactured atmosphere produced by a facility that is in continuous operation. Mars has no surface water, but there are indications that it may have substantial subsurface water that is relatively easy to reach. If so, water could be obtained by drilling in closed, pressurized facilities and piped to the habitats. Provisions would have to be made for sanitation and waste disposal. Solar power would not be reliable due to the significant difference between the perihelion and aphelion and may completely shut down during dust storms. Power would have to be provided by a nuclear reactor.

There is no evidence that Mars ever had an extensive biomass, so its soil is devoid of the nutrients necessary for agriculture. Food would either have to be synthesized or transported from Earth at a cost of tens to hundreds of millions of dollars per trip.

A central, well-equipped medical facility with easy access would need to be constructed to handle any and all health-care needs, from child birth, to serious injuries and radiation sickness.

Social interaction and transportation to work places would be through pressurized tunnels or by transportation in pressurized vehicles. Exiting from living quarters would be through an air lock. Outside activity would require pressurized suits with an oxygen supply and protection from cosmic and solar radiation. Adverse radiation effects are cumulative and cannot be completely blocked by a protective suit. Consequently, outdoor activities would be restricted due to radiation exposure and the limited supply of oxygen that an individual can carry—no more than a couple of hours. Outside activities during a Martian dust storm would be even more difficult.

Because of the environmental hazards, colonists would spend about 90 percent of their time indoors. Outdoor activities could be extended with the use of enclosed oxygen-equipped vehicles.

Beyond environmental problems, there are social and productivity concerns. What kind of indoor activities could people engage in that could justify the existence of the colony? What kinds of outdoor exploratory activities could not be done more cheaply and as effectively by robotic craft? What is the cost *versus* benefit of such an enterprise? What would Martian citizens do in their spare time? What kinds of psychological problems will arise from a prolonged life in the Martian environment? What kinds of social and political structures would evolve? How long could such a colony last without disillusion and degradation?

Mars is not a nice place to visit and I surely would not want to live there. Perhaps the funds spent on research and planning for a future colonization of Mars would be better used for taking care of Earth. There is no other place for us to go. ★

Reverse Engineering an Astronomical Image



by R.A. Rosenfeld, RASC Archivist
(randall.rosenfeld@utoronto.ca)

Abstract

Reverse engineering offers a useful approach to reconstructing the processes through which contemporary, vintage, and antique images were produced. It virtually enables back-door access to other imagers' workshops, suggesting to the observant practitioner hitherto overlooked imaging techniques, as well as forensic reconstructions of the working procedures of past imagers.

What the forger and industrial spy know...

The *Oxford English Dictionary* defines reverse engineering as: “the examination of a product in order to determine its construction, composition, or operation, typically with a view to manufacturing a similar product; the reproduction of another manufacturer's product through such a process. Also in extended use”. A statistical search with Google Ngram Viewer indicates that the phrase first appeared in print around

1943 (Google Ngram). It is probably safe to assume that the practice antedates lexical citations, computer code, and the industrial revolution, and could reasonably be as old as human technology itself.¹ It is most familiar today from its use in the commercial fields of civilian computer programming and engineering, general industrial design, and their military analogues (Kadavy 2011; Shahbaz 2012; Wang 2011). Reverse engineering also finds application in conservation science, as it does in the practice of professional forgery (Burns 2012; Hebborn 1997)—in the normal course of things, one ought not to expect successful practitioners of the forger's art to be forthcoming with the true secrets of their trade).

Prior to prying the lid off a black box to discover how it ticks, the reverse engineer ought to be armed with knowledge of the materials and techniques current when the particular black box of interest was purportedly knocked together. Actual hands-on experience regarding materials and techniques may often seem to have the edge over book-acquired learning, but both sources of knowledge can be recommended.

A discerning eye is the chief piece of equipment; all else is mere accessory. Observing something to construe how it was made is closely analogous to visual observation at the eyepiece. True observing is the art of *really* seeing what is before one's eyes; the forms of the features, their contextual positions, relative hues, saturations, luminosities, and changes, with due skepticism regarding what is or is not seen. The recording system of eye-brain-hand-logbook can hardly be reduced to

an automaton (robot) responding to the stimulation of a phenomenon by registering it on a *tabula rasa* (blank slate), for practiced judgement draws on memory, recalling reports from the storehouse of past observations (first-hand and vicarious), which invite comparison to the scene evolving at the eyepiece “in real time.” Intelligent astronomical observation—informed, critical, and analytical—can be learned and refined through use. This applies equally to the role of observation in the reverse engineering of astronomical images. What can be learned of a Victorian RASC astrosketcher's technique through careful observation of one of his images of Jupiter?

Jupiter, 1885 March 20

A.F. Miller (1851-1947) was one of the most capable members active in the Society, being numbered among those Toronto amateurs who effected its reanimation on the way to incorpo-



Figure 1 — A.F. Miller's drawing of the double transit of Jupiter on 1885 March 10.

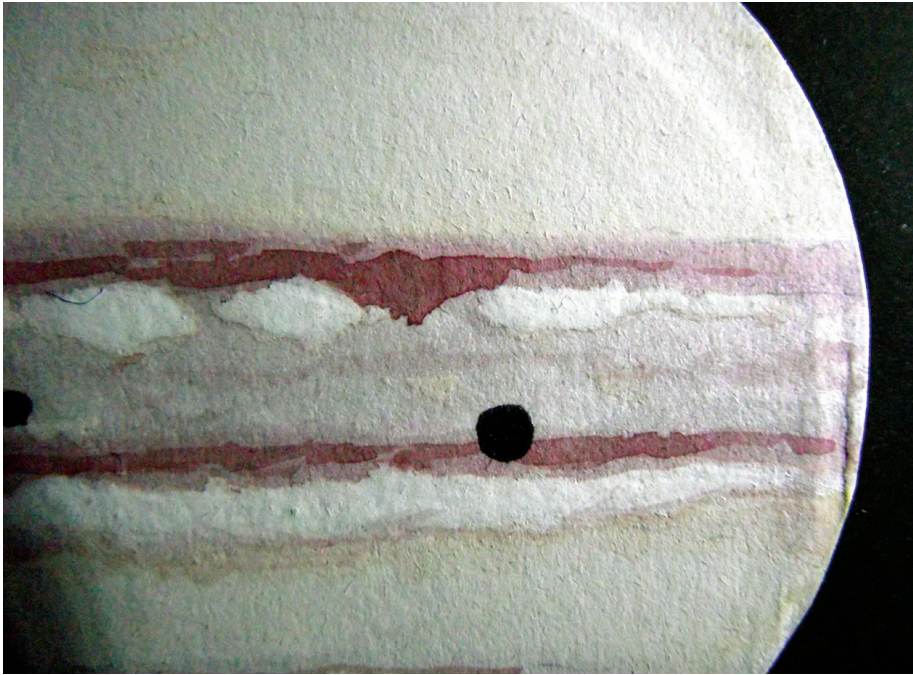

Figure 2 – Enlargement of Figure 1.

ration in 1890 (Broughton 1994, 137; but see 101). As is the practice among many amateurs, then and now, Miller spent time imaging Solar System bodies. Still extant in the leather-bound *Album of the Astronomical and Physical Society of Toronto* are several watercolours of Jupiter by Miller. That representing the observation of 1885 March 20 (Figure 1), shows among other features, a double shadow transit of two of the Galilean satellites (Io and Ganymede), and with care, one can tease out the South Polar Region, South South Temperate Zone, South South Temperate Belt, South Temperate Zone, South Temperate Belt, South Tropical Zone, South Equatorial Belt, Equatorial Zone, North Equatorial Belt, North North Temperate Belt, North North Temperate Zone, and the North Polar Region, as well as plumes and festoons in the equatorial region (Rosenfeld 2008, 203–204, fig. 5; the detail in Miller’s drawing exceeds that in the diagram in *OH 2014*, 222, and recourse must be had to Rogers 1995, 3, 42).

Miller imaged Jupiter, not through his habitual 100-mm O.G. Wray achromatic refractor, but through a 260.35-mm primary-mirror reflector (presumably silver on glass, rather than speculum), an instrument that would have been considered large among amateurs at this time, in this place. The telescope was probably the reflector belonging to his friend and colleague George E. Lumsden (Broughton, 141, 147; the instrument does not appear in Anon. 1904). No information on the ocular(s) used, or the state of the atmosphere are noted with this drawing. It should be said at the outset that the positions of Io and Ganymede seem somewhat misplaced compared to the predictions for the date and time specified by *Occult v4.0.3.0* and *StarCalc 5.73*. Several possibilities may account for this, such as an error in the recorded time (and or

date?), or a positional error in the graphic placement of the satellites and their shadows.

The media used are pencil, brush, and watercolour wash on paper (at the time watercolour paper would have been called “drawing paper”; Anon. 1890, 38). These materials would have been fairly standard and widely available to artists in Victoria’s Canada (the Queen was herself a passable watercolourist), as they are today.² Because Miller’s Jovian painting has spent most of its nearly 130-year existence in an album, it is likely that the original colour values have been largely protected from UV-induced fading. Visual inspection can provide provisional identification of the likely commercial pigments used, but more certain identification requires scientific analysis employing techniques such as

spectroscopy (Davis 1996; Fausto-Reyes 2009; Feller 2012). Here the focus will be on unravelling the sequence of work, unpeeling the layers of paint to peer over Miller’s shoulder as he worked on the drawing.

To peel back those layers usually involves modest optical aid, and while this modern work of observation was done using the Archive’s binocular microscope (*ca.* 10×–40×), a simple hand lens is often sufficient for teasing out the layers of production.

Faint traces of a light-grey pigment laid down in a consistently thin discontinuous arc can be detected around Jupiter’s limb. This is most likely discretely applied pencil lead, used by Miller to outline the planet. There also appear to be furtive traces of underdrawing in some of the belts and zones. Miller was following the common artist’s practice of laying out the general form and major features of his subject by means of a reversible draft medium, in this case pencil.

Miller then proceeded to lay down features in lighter pigments, first a yellowish light-brown wash, followed by grey washes, then very light rose washes, and finally white (including the satellites near the planet). The darker colours followed, with the painting of dark rose and mauve cloud features. Finally, the satellite transits were added in black (how accurate are the shapes of the transiting “shadows”?).

This sequence can be discerned solely through the telltale evidence of overlapping colours (Figure 2).

One aspect of Miller’s practice that might strike modern astronomical artists as odd is that the image of Jupiter was cut out, and pasted onto the black background page. A lone spot of glue residue can even be detected, at the border between the Jovian limb and interplanetary space (as it were), in the

quadrant that presents at the viewer's lower right (Figure 1). Visual inspection suggests an animal-source glue such as isinglass, although without proper scientific sampling and analysis this should be treated with caution. The practice of pasting planetary disks onto dark backgrounds is frequently encountered in 19th- and early 20th-century astronomical albums and in some logbooks. It is not a practice many would follow now, because of the perceived difficulties in cleanly cutting the oblate planetary forms, and gluing them without leaving the bonding agent visible (both faults are evident in Miller's sketch).

It is worth remarking that Miller's image is unlikely to be his original observational sketch done at the eyepiece, for the simple reason that filtered light (such as the amber-coloured light in Lord Rosse's astronomical lantern; Block & Freeman 2009, 70-72), or dim light will alter the perception of colours. This is a second- or third-generation observational sketch, based on monochrome sketches with notes about the colours seen, or memory alone, or more likely a first-generation monochrome observational sketch mediated by memory.³

Miller's sketch, while not the most scientifically detailed, or artistically striking of the period, is not unpleasant to the eye. Readers may find it enlightening to compare his sequence of work with their own or with recent modern prescriptions for sketching the planet (Rosolina 2014).

Is there an astronomical image you really admire? Or, is there a master of astronomical observational art whose "secrets" you'd like to learn, but who unfortunately can no longer be contacted? If so, then you can still learn from the notable practitioners of the discipline through learning to reverse engineer their work. It is a skill well worth cultivating. Of course, the true test of what you've learned is put into practice in the field and studio. Perhaps in time others will want to reverse engineer *your* astronomical art. ★

References

Manuscripts, Books, and Articles

- Anon. (1890). *Windsor & Newton's Catalogue of Colours and Materials...* London: Windsor & Newton, Ltd.
- Anon. [Harvey, A.?] (1904). The Astronomical Equipment of Canada, *The Royal Astronomical Society of Canada, Selected Papers and Proceedings 1902-1903*, 52-60
- Bell, T.E. (2005). A Planetary Pioneer, *Astronomy* 33, 3, 74-77
- Block, D.L. & Freeman, K.C. (2009). *Shrouds of the Night: Masks of the Milky Way and our Awesome new View of Galaxies*. New York: Springer
- Broughton, R.P. (1994). *Looking Up: a History of the Royal Astronomical Society of Canada*. Toronto-Oxford: Dundurn
- Burns, T. (2012). *The Luminous Trace: Drawing and Writing in Metalpoint*. London: Archetype Publications
- Fausto-Reyes, C. et al. (2009). Raman Spectroscopy for the Identification of Pigments and Color Measurement in Dugès Watercolors,

Spectrochimica acta Part A: Molecular and Biomolecular Spectroscopy, 74, 1275-1279

- Feller, R.L. et al. (2012). *Artists' Pigments: A Handbook of Their History and Characteristics*, 4 vols. Washington-London: National Gallery of Art and Archetype Press
- Hebborn, E. (1997). *The Art Forger's Handbook*. London: Cassells
- Hovers, E. (2010). *The Libtic Assemblages of Qafseh Cave*, Human Evolution Series. New York: Oxford University Press
- Kadavy, D. (2011). *Design <for> Hackers /*reverse-engineering beauty*/*. Chichester: John Wiley & Sons, Ltd.
- McKim, R. (2004). Nathaniel Everett Green: Artist and Astronomer, *JBAA* 114, 1, 13-23
- OH: *Observer's Handbook 2014*, (Ed.) D. Chapman. Toronto: Royal Astronomical Society of Canada
- Rogers, J.H. (1995). *The Giant Planet Jupiter*, Practical Astronomy Handbooks 6. Cambridge: Cambridge University Press
- Rosenfeld, R.A. (2008). Astronomical Art and Artifact: the View from the Archives, *JRASC* 102, 5, 200-205
- Shahbaz, M. (2012). *Reverse Engineering and Testing of Black-Box Software Components*. Saarbrücken: Lambert Academic Publishing
- Wang, W. (2011). *Reverse Engineering: Technology of Reinvention*. Boca Raton: Taylor & Francis Group, LLC
- Warner, B. (1983). *Charles Piazzi Smyth, Astronomer-Artist, His Cape Years 1835-1845*. Cape Town and Rotterdam: A.A. Balkema

Web sites

- Google Ngram Viewer, reverse engineering
<http://tinyurl.com/qb95grm> (accessed 2013 December 1)
- OED: Oxford English Dictionary, reverse engineering, *n*.
www.oed.com/view/Entry/275550? (accessed 2013 December 1)
- The Book and Paper Group Annual, 15 (1996), M.J. Davis, A Study of Visual Techniques for Identification of Watercolor Pigments
<http://cool.conservation-us-org/coolaic/sg/bpg/annual/v15/bp15-07.html> (accessed 2014 February 3)

Endnotes

- 1 Establishing specific instances in the remote archaeological record is not easy. Any readers game to try with middle-Palaeolithic material can assay the Qafseh assemblages—if they dare; Hovers 2010.
- 2 One of Queen Victoria's art instructors was the professional watercolourist and planetary artist N.E. Green; McKim 2004.
- 3 From what Trudy Bell has written about Walter Haas' training under William Pickering, one could construe the training to have imposed the discipline of only sketching while at the eyepiece and making copious notes about colour among other details, and never adding anything from memory when away from the eyepiece (Bell 2005, 74). On the other hand, it is known that Charles Piazzi Smyth, an excellent astronomical draughtsman of reputed accuracy, commonly did his astronomical drawings the morning after observing, without making any notes at the eyepiece (Warner 1983, 111).

Galaxy Crossword

by Naomi Pasachoff

ACROSS

1. Home to General Dynamics Armament Systems
5. Ninth letter of Hebrew alphabet
9. Shattered
14. Keto-_____ tautomeric equilibrium
15. Jai _____
16. Lotharios
17. Grand Theft Auto IV luxury car manufacturer
18. Where experimentalists work
19. Prefix with -genic
20. Among the largest known structures of the cosmos
23. Science Channel's two-part miniseries "Are We _____?"
24. Frequency range used by AMSU and SSMI/S
25. Marijuana
28. Succeed
29. Chilean Nobel laureate poet Pablo
33. One of the Nereids
34. Joel Chandler Harris Uncle
35. Spoke
37. His observations showed that a galaxy's recessional velocity increases with its distance from Earth, implying an expanding Universe
39. Finally
41. Uneven, like some leaves
42. Mendel's subjects
43. Dry gulch
45. ____ Bintang, Indonesian "star" lager
48. Honi Coles dance form
49. The cravat was its forerunner
50. American sports and news broadcasting pioneer Arledge
52. Subject of Shapley-Curtis debate
57. Wept

1	2	3	4		5	6	7	8		9	10	11	12	13
14					15					16				
17					18					19				
20				21						22				
23								24				25	26	27
28				29	30	31	32				33			
			34						35	36				
			37						38					
39	40						41							
42					43	44						45	46	47
48				49						50	51			
			52	53				54	55	56				
57	58						59					60		
61							62					63		
64							65					66		

59. Aquatic bird
60. Certificate holders in this field teach immigrant children
61. Distant cousin of Ebola
62. Restrictive pattern
63. A Great Lake
64. Creator of telescope mirror for the GMT
65. What some astronomers bring to some observatories for recreation
66. Jack Kerouac's *On the _____*
8. Made a sound of disapproval
9. Stephen Hawking's *A _____ History of Time*
10. Leonine utterance
11. Declared openly
12. A Kelvin function
13. Its facilities include the VLT, APEX, ALMA, and E-ELT
21. Makes effective for an additional period
22. "*_____ took my love away*": The Beatles
26. Number of Earth's moons
27. Conferences whose logo is "Ideas Worth Spreading"
30. What deflating balloons do
31. Participate in a marathon
32. Theater employee
33. *Winnie _____ Pu*
34. Nutritional information guidelines created during WWII
36. Take in radiation
37. Slipping by
38. Prefix meaning "tail"
39. Likely
40. Earl Grey or Lapsang Souchong
44. Some Renaissance cosmologists believed in three _____
45. Maurice Ravel's most famous composition
46. Cheomseongdae is the oldest existing astronomical observatory _____
47. Brought in a fish
49. Forces responsible for huge X-ray flares in some galaxies
51. The gas giants are _____ planets
53. Nickname of third man to walk on the Moon
54. Behold
55. _____ me tangere
56. Are they justified by the means?
57. Half a Latin dance
58. Kurosawa's *King Lear*

DOWN

1. Playground mainstay
2. Ring-shaped structures like that at certain eclipses
3. They are coveted by shoppers
4. Actress twins Mary-Kate and Ashley
5. Bath powder
6. Israel's national airline
7. Proscribed as unacceptable

Cosmic Contemplations

No Requiem for a Cassegrain Reflector



by Jim Chung, Toronto Centre
(jim_chung@sunshine.net)

I would wager that a majority of readers have more than one telescope and more than one type of telescope, because you need one for every occasion. Visual or imaging; wide-field, deep-space or high-focal-length planetary; eclipse-chasing back-pack or pier-mounted roll-off-shed—one must match the application with the appropriate instrument. My planetary-imaging telescope of choice has been a 12" Skywatcher $f/5$ collapsible Newtonian mounted on a Skywatcher EQ6, but I've always disliked its weight and the need to stand precariously on a chair to view through the finderscope. Being budget minded, I planned to convert the Newtonian into a classical Cassegrain reflector (Figure 1). This would allow me to reuse the parabolic primary mirror and tube structure, though requiring that a compatible hyperbolic convex secondary be fabricated. Instead of drilling a central perforation through the primary mirror, I would redirect the image to an eyepiece with a diagonal flat secured with adhesive to the primary's centre.

Just when all seemed lost, I had a chance meeting with a scope nearly as old as myself. A 12" $f/13$ classical Cassegrain and its 24" big brother were installed in 1968 at York University, located in the northern end of Toronto. The scopes were made by *Competition Associates* of Cambridge, Massachusetts—a company that started life as a tuner garage for fast, high-end sports cars owned by well-heeled Harvard University students. The owner of the company had contacts with the Smithsonian Institute in Washington, D.C., and built them a fork-mounted

camera platform. A telescope subsidiary was subsequently born. Ealing Corporation, a large UK firm with a long history of microscope making, bought out *Competition Associates* in the same year, and this line of reflectors became widely known as the Ealing Educator/Research series with aperture sizes ranging from 8" to 24". Ealing promoted the 8" scope as a breakthrough in pricing at just under \$3000, or the average price of a new car in 1970. The scopes featured optics made by *The Optical Craftsmen*, a custom fibreglas tube, and a massive cast-iron mount with *Byers* gears, and *Timkin* tapered roller bearings driven by synchronous AC motors. Dick Nelson, founder of *The Optical Craftsmen*, revealed in a 1997 interview shortly before his death that his optics were consistently figured to a value of 1/20th wave and that he ground optics for institutional telescopes up to a maximum aperture of 24". The scope saw faithful service despite being abused by undergraduate students dropping wrenches into it, and it was replaced in the summer of 1999 by the current 16" Meade SCT. The complete system was donated to a small club, and for the next decade remnants of only the OTA circulated amongst amateur astronomers; it was even acquired as seized property in lieu of payment, and then it found me.

Open-design reflectors offer advantages in cool-down time and weight reduction, and the minimalism is personally appealing. I was pleasantly surprised to discover that such designs are hardly new. Horace Dall, a British optician, formulated a modified Cassegrain design in 1932 that used an aspherized paraboloid as the primary and a spherical mirror for the secondary (which is much easier to make). Alan Kirkham of Oregon independently arrived at the same design a few years later, hence the Dall-Kirkham Cassegrain variant that is found commercially in the Takahashi Mevlon line of reflectors. In 1947, Dall built a clever folding 3.5" Dall-Kirkham reflector that could be placed in a vest pocket (Figure 2), and we've been emulating the master ever since.

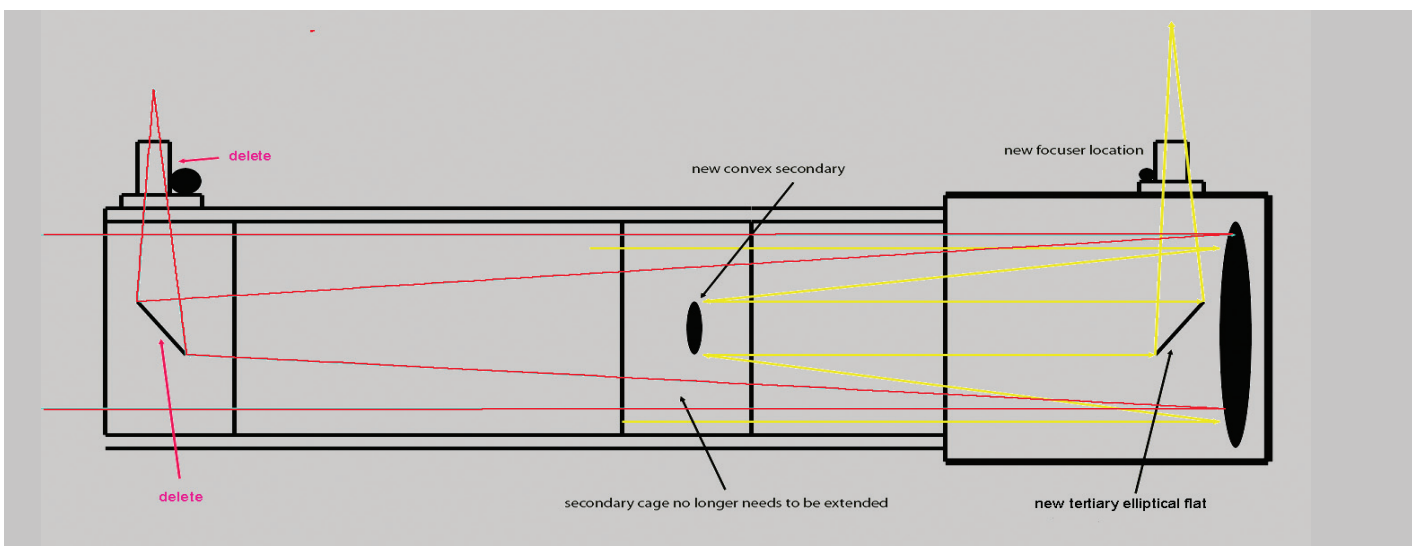

Figure 1 — The original plan—to convert a Newtonian into a Cassegrain.



Figure 2 — Horace Dall's vest-pocket Cassegrain.

The optics and their respective mirror cells were in fine condition, although they were the only salvageable items. The specifications of the optical set were hand engraved on the back of the secondary, including the important separating distance between the faces of the primary and the secondary. The primary mirror cell was mounted between two sheets of ¼" thick and 18" diameter aluminum that had been custom cut with ventilation holes at AC Waterjet, a Toronto company that specializes in precision computerized high-pressure water-stream (with abrasive particles), cutting of all manner of materials and thicknesses. I suspect that my project was one of their easier jobs. The central baffle tube was constructed of 2" diameter ABS plastic plumbing components (Figure 3) and thin aluminum sheet baffles cut with hole saws. The baffle tube itself was mounted independently of the primary mirror so that it would not impose any strain on the glass and so that it could be collimated on its own.



Figure 3 — ABS plastic components of the telescope baffles.

An 18"-diameter plywood ring suspended the secondary cell via a four-vane spider and a long ¼-20 bolt (Figure 4), so that the position of the secondary relative to the primary could be varied. The secondary cage was attached to the primary cage by three 1.3"-diameter carbon-fibre poles with an internal bore of 1 1/8" riding on six 4"×1 1/8" solid-aluminum tubes. The

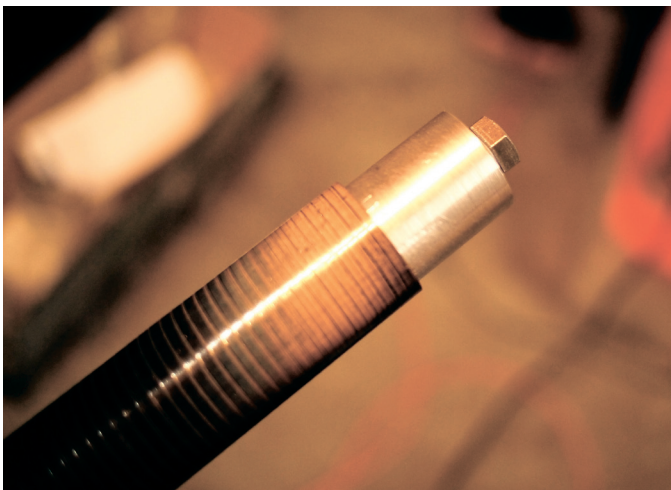

Figure 4 — The support bolt for the secondary

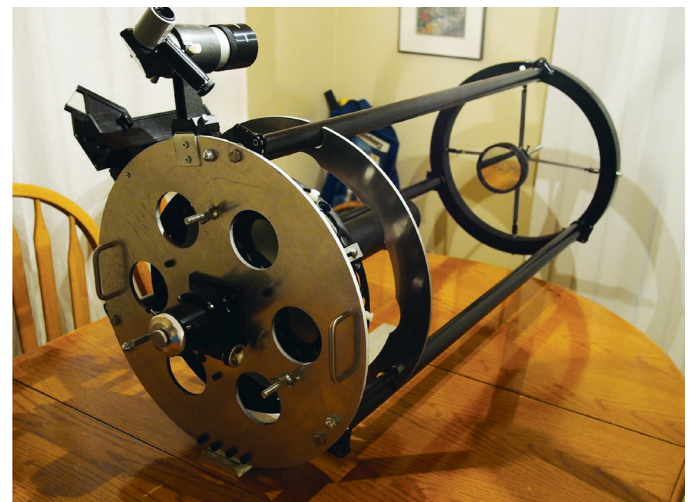

Figure 5 — The completed telescope, ready for use.

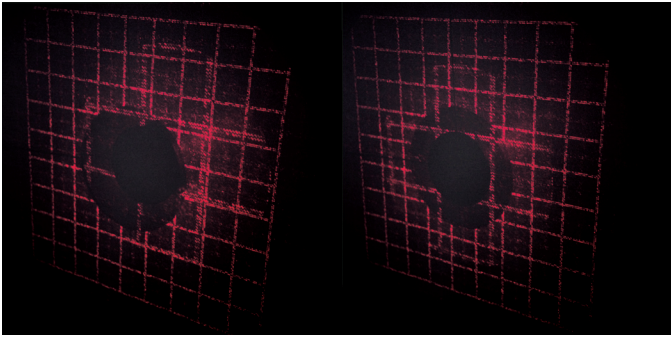

Figure 6 — Laser collimator target patterns. The left-side image shows the dark shadow of the secondary off to the right side; the right image shows the final, collimated alignment

poles were secured to the aluminum tubes with quick-release mountain-bike seat-post clamps. The focuser is a vintage JMI NGF Crayford with an analogue DRO, flat-surfaced mounting flange, and collimating Allen bolts. A Telrad and 9×50 right-angle finderscope with an illuminated Surplus Shed etched-glass reticle complete the package.

Initially, the collimation process appeared daunting, given all the adjustable regions of the scope, but it was simply a matter of making all the optical surfaces square with each other. The spider vanes were adjusted until the secondary was centred with the focuser. A 2" Hotech laser collimator was inserted in the focuser, and it was adjusted until the beam hit the centre of the secondary. The secondary was adjusted until the return beam hit the Hotech's scribed crosshair markings and voilà, the focuser and secondary were collimated. A 2" Howie Glatter holographic laser collimator was inserted into the focuser and its red grid pattern thrown up onto a projector screen. With this setup, the fainter grid pattern, reflected off

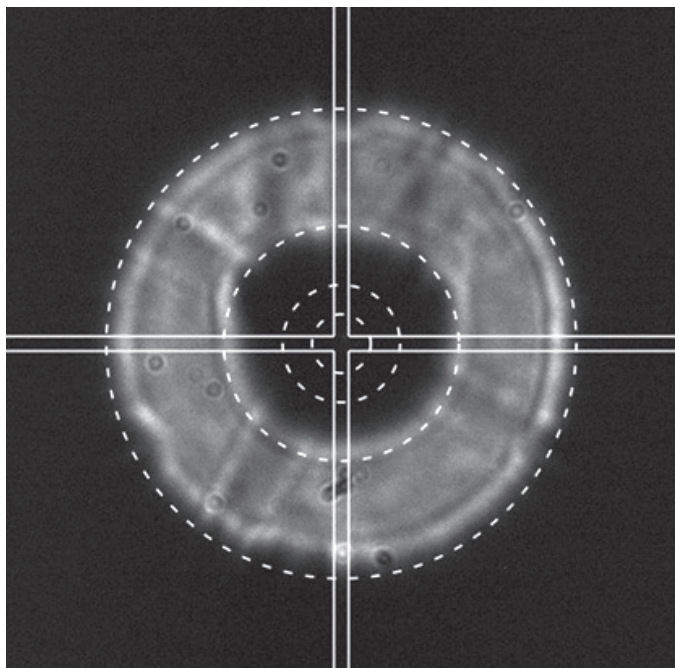

Figure 7 — An out-of-focus star in the perfectly aligned telescope

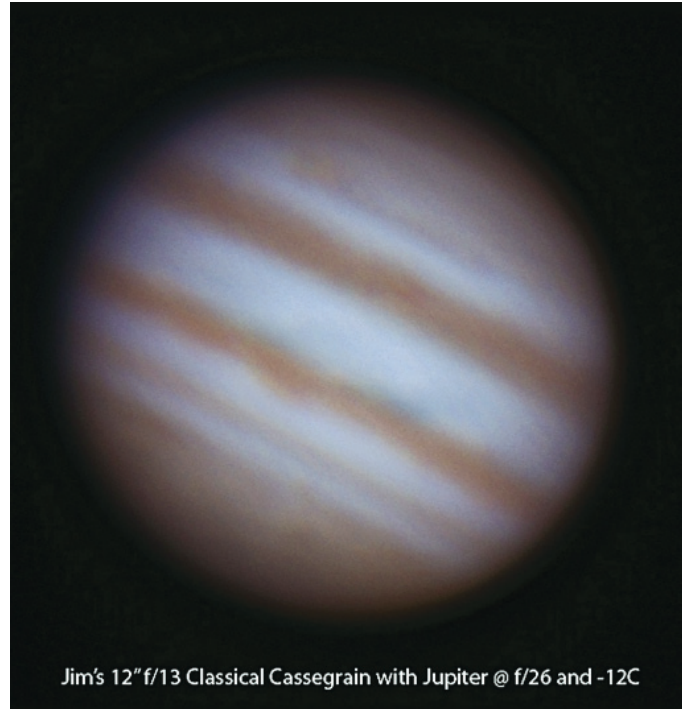

Figure 8 — Jupiter in poor seeing, hinting at the capabilities of the new telescope.

the secondary and onto primary, is shown superimposed on the brighter grid pattern emanating directly from the focuser (Figure 6). When the two grid patterns were properly centred, the primary was adjusted and collimated to the secondary.

Of course, absolute collimation is best performed on a star. I found it much easier to use one of my planetary imaging cameras, a 2× Barlow, and a slightly defocused star to do this. An overlaid reticle pattern made it very easy to determine when all the concentric rings were correctly centred.

At the time of writing, Toronto has been captive to polar vortices all winter, and I only had one opportunity to image Jupiter with the scope under very mediocre seeing conditions. Unfortunately, I cannot end with a glorious high-resolution image, but I am very confident of the optics. The scope is significantly lighter than the Newtonian it is replacing, and I no longer need to double-stack Barlows to achieve $f/20$ to $f/30$ focal lengths, which is sure to improve image quality. More importantly, the legacy of an important optical instrument has been preserved, valuable resources have been recycled, and I've been granted yet another stay from the Editor of the JRASC. ★

Jim Chung has degrees in biochemistry and dentistry and has developed a particular interest for astrophotography over the past seven years. He is also an avid rider and restorer of vintage motorcycles, which conveniently parlayed into ATM (amateur telescope maker) projects. His dream is to spend a month imaging in New Mexico away from the demands of work and family.

John Percy's Universe

Toronto's Astronomical Heritage

by John R. Percy

(john.percy@utoronto.ca)

In addition to the very successful national projects during International Year of Astronomy (IYA2009) in Canada (Hesser *et al.* 2010), astronomers were encouraged to develop their own personal projects, and I have already described some of mine (Percy 2012). As a member of Heritage Toronto and a participant in their heritage walks program, I decided to develop a walking tour of the many astronomically significant sites on and around the University of Toronto (U of T) campus. These date from 1840, though Canada's Aboriginal peoples had been using the sky for practical and ceremonial purposes for untold centuries before. Continuing a partnership begun during IYA2009, I have also given presentation versions of the walk in branches of the Toronto Public Library. The walk and presentation illustrate how astronomy has grown in parallel with the university, the city, and the country.

By 1800, the Copernican/Galilean revolution had taken place, and science and public interest in science were flourishing—in Europe. Toronto (then called York) was a frontier village. Only a handful of people would have known some practical or descriptive astronomy. York became the capital of Upper Canada in 1793. Its population rose from 720 in 1812 to 31,775 in 1851. The Town of York became the City of Toronto in 1834. Upper and Lower Canada became Canada West and East in 1841. By mid-century, Toronto was becoming a major centre for manufacturing, transportation, and finance.

Toronto and Canada Come of Age

In 1840, the British Admiralty established a magnetic observatory in Toronto as part of an international project to understand why compass needles “wandered” on time scales of hours to years. When the project was completed and the cause—solar-terrestrial interactions—was discovered and published, the observatory was dismantled and the instruments taken “home.” But the colonial government wisely decided that the fledgling country should have its own observatory, so the Toronto Magnetic and Meteorological Observatory (TMMO; Figure 1) was built as a national centre for meteorology and timekeeping.

Astronomy also had important applications to surveying; latitude and longitude were determined by observations of the altitudes and transit times of the Sun and stars. A pillar, near TMMO, marks the “official” position of Toronto for surveying purposes. Other positions could be determined, relative to this. Another plaque commemorates TMMO itself.

Sir Sandford Fleming (1827–1915), engineer, surveyor, mapmaker, railway builder, and entrepreneur, was an important figure of the time. He is best known as a vocal and successful proponent of Standard Time. He also developed Canada's first postage stamp (1851) and co-founded the Royal Canadian Institute (RCI, 1849) and the Royal Society of Canada (RSC, 1882). The RCI was an outgrowth of the “mechanics institute” movement as a forum for the public communication and discussion of science and technology. It played an important role in Canadian science in the late 19th century, and is Canada's oldest still-existing scientific society, though its present role is primarily the communication of science to the public¹.

In 1868, a group of eight “laymen” gathered to discuss astronomy. Their “Toronto Astronomical Club” evolved into our beloved RASC, which provides a variety of activities and publications of interest to amateur astronomers and which is especially known for its outreach activities. It was awarded the national *Michael Smith Award* in 2003, for excellence in bringing science to the public.

U of T received its charter in 1827, but the powers-that-be could not decide whether the university should be Anglican or secular. The Anglicans, under Bishop Strachan, established their own Trinity College on a different site, and it was not until 1853 that teaching began, in temporary premises, at the U of T. A permanent building—now University College—was completed in 1859.

In the meantime, the Methodists had established Victoria College in Cobourg in 1836. The founding president was Egerton Ryerson, the “father” of public education in Ontario. In his inaugural address, he stated that “surely the knowledge of the laws of the universe, and the works of God, are of more practical advantage, socially and morally, than the knowledge of Greek and Latin.” Victoria College moved to the U of T in 1892, occupying a building (now known as “old Vic”) that now also hosts the Institute for the History and Philosophy of Science and Technology (IHPST²). Its most famous faculty member was Galileo scholar Stillman Drake (1910–1993). Since IYA2009, IHPST has partnered with the astronomy department in a number of history-of-astronomy projects, including the 2012 Transit of Venus. TMMO purchased a telescope especially to observe the 1881 transit, but it was cloudy—not unusual in Toronto in November!

A group of enterprising IHPST graduate students have created the University of Toronto Scientific Instrument Collection³, dedicated to cataloguing and conserving the university's historical scientific instruments. Our astronomical instruments were catalogued in 2012 as a “Transit of Venus” project.

Entering the 20th Century

As the turn of the century approached, the university grew. Independent professional schools such as medicine (1887), engineering (1906), and education (1907) affiliated with the

university, as did faith-based colleges such as St. Michael's (1881), Victoria (1892), and Trinity (1904). The university was now responsible for providing lecture and laboratory instruction in the sciences for all these students. New buildings were needed, and the TMMO site was prime real estate. One such construction was the Physics Building, including astronomy, which was opened in 1907. It was rebuilt after a disastrous fire in 1977, repurposed (for electrical engineering) and renamed the Sanford Fleming Building.

In 1907, the Meteorological Service moved to 315 Bloor Street, which is now part of the Munk Centre. The telescope tower is still prominent, the transit building less so. It subsequently moved to its present location at 4905 Dufferin Street in 1971. TMMO was to be demolished, but surveying instructor Louis B. Stewart came up with the bright idea of disassembling it, stone by stone, and moving it a few hundred metres to its present site on a hill, just south of Hart House. It is now the Stewart Observatory and is the home of the University of Toronto Student Union.

Clarence Augustus Chant (1865-1956) joined the growing physics department in 1891, and immediately turned to teaching astronomy. He established a separate astronomy department, with its own courses and programs, in 1905. His popular articles and books, and public lectures led eventually to the donation (by Jessie Donald Dunlap) of the David Dunlap Observatory (DDO), which opened in 1935 with the second-largest telescope in the world. The small staff included Helen Sawyer Hogg (1905-1993), Canada's best-known (as a result of her weekly astronomy column in Canada's largest newspaper for over 30 years) and most beloved astronomer.

The Royal Ontario Museum (ROM) opened in 1914, but its roots go back to the work of Egerton Ryerson and the RCI. In the 1950s, it sponsored important studies of the "New Quebec" meteorite impact crater, spurring Canadian interest and expertise in this topic. It now hosts one of the world's best collections of meteorites, especially rare carbonaceous chondrites.

The Post-War Years

The end of WWII brought several developments that had a direct or indirect impact on astronomy. Returning veterans were offered free education, and many chose engineering. At U of T, new buildings were again required, and a temporary campus was created in Ajax to accommodate the overflow.

Electrical engineering flourished, and some engineers with expertise in radar developed an interest in radio astronomy. At the U of T, electrical engineer Jui-Lin (Allen) Yen collaborated with astronomers to carry out the first successful Very Long Baseline Interferometry experiments. These were honoured by the award of the Rumford Medal in 1967. Astronomers Jack Heard and Don MacRae were among the first to use FERUT, the university's Ferranti computer. The University of Toronto Institute for Aerospace Studies (UTIAS) later developed expertise in space astronomy, playing a major role in the



Figure 1 — The Stewart Observatory, previously the Toronto Magnetic and Meteorological Observatory (1853), now occupied by the University of Toronto Student Union.

development of *MOST*⁴ (*Microvariability and Oscillations of STars*: Canada's "Humble Space Telescope") and more recently a "constellation" of *BRITE*⁵ (*BR*ight *T*arget *E*xplorer) nanosatellites, which can measure the variability of the brightest stars with unprecedented accuracy.

In 1946, J. Tuzo Wilson (1908-1996) became Canada's first Professor of Geophysics, and this became an area of great strength at the U of T. There are now strong programs in Earth and planetary science on both its downtown and Scarborough campuses.

The post-war years also created a baby boom that led to an expansion of the school system in the 1950s—with the need to rapidly train thousands of teachers—and the university system in the 1960s. York University began as part of the University of Toronto (1959-1965) and then became independent. It has a strong astronomical research group, and excellent public education programs⁶. The U of T created new campuses in Scarborough (1966) and Mississauga (1967), and these and other newly created or expanded campuses across the country provided dozens of new jobs for astronomers—including me.

The Space Age and exciting developments in astronomy fuelled public interest. The U of T and the RASC promoted the creation of the McLaughlin Planetarium (1968-1995) as part of the ROM. It was one of the world's major planetariums and also home to the RASC Toronto Centre until its unfortunate and unnecessary closing in 1995, ostensibly due to the provincial government's "common-sense revolution" budget cutbacks. The ROM continues to offer astronomy education programs with small, portable planetaria.

The Ontario Science Centre opened in 1969 as a slightly belated centennial project of the provincial government. It has continued to flourish, often being Canada's most-visited cultural facility. It has excellent astronomy exhibits and programs, a small but powerful planetarium, and has been home to the RASC Toronto Centre⁷ since 1995.

The Modern Era

Astronomy has changed dramatically in the last generation. In the 1970s, the DDO continued to be productive in research (the first black hole in space was co-discovered there in 1971-1972) but, by then, astronomers had adopted superb observing sites in Hawaii and Chile. Canada became a partner in the Canada-France-Hawaii Telescope. The U of T built a small but very productive 0.6-m telescope on Cerro Las Campanas in Chile. Sadly, it was later taken over by and moved to Argentina because of cutbacks to science funding in Canada.

Use of the DDO for research and student training declined and, in 2008, the DDO lands were sold by the U of T to a developer and the proceeds used to endow a new Dunlap Institute⁸ on the university campus, carrying the Dunlap name and bequest forward into the 21st century. Astronomical instrumentation, observation, and education and public outreach are the core of its mission. DDO is still operated, effectively and successfully, as a public outreach facility by the RASC Toronto Centre⁹.

An under-appreciated “jewel” in Canada’s science crown is the Canadian Institute for Theoretical Astrophysics¹⁰, a world-class, cost-effective centre, hosted by U of T, for research in theoretical and computational astrophysics. Its former director, Richard Bond, is Canada’s most-honoured astronomer.

Canada was a relatively late player in space astronomy—but recall that we were the third country to have a satellite in space, after the USSR and the USA. Canadian astronomers have been active users of NASA and ESA satellites and their data, but *MOST* is the first Canadian space observatory.

The U of T is also a centre for balloon astronomy—a low-cost way of placing microwave telescopes above 99 percent of the atmosphere. Missions such as BOOMERANG and BLAST¹¹ have provided important information about the cosmic microwave background radiation and about the star-forming gas and dust in the Milky Way.

There are now over 50 faculty and postdoctoral astronomers at the U of T and over 30 graduate students.

As for the teaching of astronomy: in some ways it has changed (technology; the topics we teach: exoplanets, black holes, dark matter, dark energy), and in some ways it is the same. Although we teach courses of up to 1350 students, the courses succeed because the instructor understands pedagogy, can communicate, is enthusiastic, and cares about students. We have major and specialist programs for undergraduates, and one of the best graduate programs in astronomy anywhere. And public outreach is as important to us, as much part of our work, as it was to Chant, a century ago.

References and Resources

The script for my astronomical heritage walk¹² and the slides for the library version of the walk¹³ are available on my Web

site¹⁴. Don Fernie has written an excellent short history of astronomy at the U of T¹⁵ and I have prepared a short history with links to about 40 subtopics¹⁶. Jarrell (1988) is the definitive history of Canadian astronomy to 1988. ★

References

- Hesser, J.E. *et al.* (2010). An Initial Retrospective on the International Year of Astronomy 2009 in Canada. *JRASC*, 104, 51.
- Percy, J.R. (2012). A Half-Century of Astronomy Outreach: Reflections, and Lessons Learned. *JRASC*, 106, 240.
- Jarrell, R.A. (1988). *The Cold Light of Dawn: A History of Canadian Astronomy*. Toronto, ON: University of Toronto Press.

Endnotes

- 1 <http://royalcanadianinstitute.ca>
- 2 www.hps.utoronto.ca
- 3 <http://utsic.escalator.utoronto.ca>
- 4 <http://most.astro.ubc.ca>
- 5 www.asc-csa.gc.ca/eng/satellites/brite/
- 6 <http://astronomy.blog.yorku.ca>
- 7 <http://toronto.rasc.ca>
- 8 <http://dunlap.utoronto.ca>
- 9 <http://theddo.ca>
- 10 <http://cita.utoronto.ca>
- 11 <http://blastexperiment.info>
- 12 www.astro.utoronto.ca/~percy/heritagewalk.pdf
- 13 www.astro.utoronto.ca/~percy/heritagetalk.pdf
- 14 www.astro.utoronto.ca/~percy/EPOindex.htm
- 15 www.astro.utoronto.ca/about/History
- 16 http://sce.library.utoronto.ca/index.php/Astronomy_at_the_University_of_Toronto

John Percy is Professor Emeritus, Astronomy & Astrophysics, and Science Education, University of Toronto, and Honorary President of the RASC.

It’s Not All Sirius

by Ted Dunphy



Second Light

Into the Mixing Bowl



by Leslie J. Sage
(l.sage@us.nature.com)

Stars form from dense cores inside molecular clouds—clouds made mostly of molecular hydrogen with a mixture of other molecules such as carbon monoxide. The cores start off more or less spherical, but during the collapse, a disk forms, and out of such disks, planets form. Nami Sakai of the University of Tokyo and a global group of collaborators have found that, during this process, the chemical makeup of the gas undergoes a rather sharp and unexpected change at a particular place where the gas is going through a transition region before it enters the disk (see the March 6 issue of *Nature*—first published online on 2014 February 12).

During the protostar stage, while the star is still growing through the accretion of gas, it is surrounded by a flattened envelope that is rotating and collapsing, feeding gas into the disk, which in turn feeds it into the star. The density of the gas changes by many orders of magnitude during this process, and even from the envelope to the disk, it increases by a factor of a thousand. In addition, the temperature increases from ~10 K in the envelope to ~100 K in the disk. The general outlines of this process have been evident for about 30 years, but now the amazing ALMA telescope in northern Chile (*JRASC* 107, 134) can study the process with unprecedented resolution and sensitivity.

Sakai and her colleagues were studying a protostar with the very unglamorous name of IRAS 04368+2557 in the Taurus molecular cloud, which is a nearby cloud making a lot of low-mass stars. The envelope has a radius of ~500 AU, and the disk a radius of ~90 AU. (The name comes from the position of the source in the IRAS catalogue, which came from observations of the *InfraRed Astronomical Satellite*—a hugely successful mission in 1983-1984.) The envelope and disk were previously known, but no one had ever previously thought—nor been physically able—to track the changes in gas chemistry across the entire disk/envelope region.

One of the powerful aspects of ALMA is that, in addition to the high spatial resolution, it is able to observe many more spectral lines simultaneously than any previous instrument. This allowed Sakai to study simultaneously how the molecules of cyclic- C_3H_2 (cyclo-propenylidene) and SO (sulfur monoxide) behaved. The $c-C_3H_2$ showed the classic pattern of rotation and infall expected for protostellar envelopes, but surprisingly, the $c-C_3H_2$ completely disappeared at a radius of ~100 AU from the star. In contrast to that, the SO molecules are confined to the disk. There is no evidence for them in

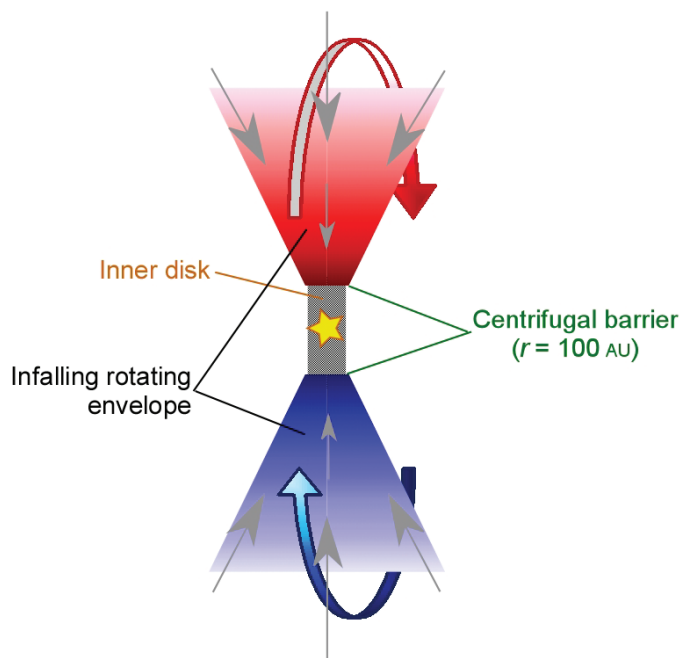

Figure 1 — A toy model illustrating the basic structures associated with the gas falling from the envelope towards the disk. Image courtesy of Nami Sakai and *Nature*.

the envelope. Even more interesting, the SO appears to be confined to a relatively thin ring whose radius is close to that of the inner edge of the distribution of the $c-C_3H_2$. Something is driving a rather substantial change in chemistry in a fairly small region of space.

Sakai then looked at how the physical properties of the gas changed over this region. In the envelope, the gas temperature is in the 23-30 K range, while the temperature of the SO gas is higher than 60 K. The sublimation temperature of SO from icy grains is ~50 K, so she proposes that the SO is liberated from grains as they pass through what is called the “centrifugal barrier” at a radius of ~100 AU. Closer to the protostar, the SO is likely again depleted onto icy grains on a timescale of just 10-200 years, explaining why it is seen only near the transition region.

The “centrifugal barrier” deserves some additional explanation. One of the key elements is the conservation of angular momentum, a fundamental law of physics. The gas in the envelope is both falling towards the protostar, and rotating slowly. Moving gas has kinetic energy, and the infalling gas cannot move inwards of the centrifugal barrier until the kinetic energy associated with the infall has been converted to rotational motion. This location is the radius at which the rotational velocity is at a maximum, where the infall energy has been converted to rotational energy.

Conversion of energy from one form to another is rarely 100 percent efficient. At the barrier, there is energy available to heat the gas, which likely accounts for the liberation of the SO and the destruction of the $c-C_3H_2$, perhaps through interactions with oxygen atoms.

Chemical models of disk formation have hitherto assumed that the chemistry changes smoothly during disk formation. This is clearly incorrect for this source, and given that the basic physics of the centrifugal barrier must apply to all such protostars, by extension, there is a potentially large problem modelling the chemical processing of gas during the accretion process. It is too early to say how big a problem this might be, but this discovery illustrates why astronomers want revolutionary telescopes like ALMA—while the science case made to funding agencies is based upon extrapolations of existing

science, the true value of such telescopes lies in the totally unexpected things they find. Expect a lot more unexpected discoveries from ALMA over the next decade. ★

Leslie J. Sage is Senior Editor, Physical Sciences, for Nature Magazine and a Research Associate in the Astronomy Department at the University of Maryland. He grew up in Burlington, Ontario, where even the bright lights of Toronto did not dim his enthusiasm for astronomy. Currently he studies molecular gas and star formation in galaxies, particularly interacting ones, but is not above looking at a humble planetary object.

2014 General Assembly of the RASC: Call for Papers



It's time again for the Call for Papers for the Annual General Meeting of the RASC. If you are considering taking in the beautiful surroundings of Victoria, B.C., at the end of June 2014, why not think about a topic that you would like to share with fellow astronomers? The papers can be about some observational research you may be involved with, the photographs

of a trip you've taken, or a new outreach program that has been started by your Centre. Have you done some historical research, worked on a new educational program, or have a unique point of view on an astronomical topic? We are looking for presentations that represent a wide variety of topics generally related to astronomy and would love to have you involved.

Our paper presentations will be held on Saturday, June 28 and will be, as in the past few years, 15 to 20 minutes in length. They are one of the showcases of the Annual General assembly and are eagerly anticipated by the delegates. We hope you will consider a proposal.

On Sunday, June 29, we will be having an afternoon forum that has as its theme the RASC's intentions for programs and initiatives for UNESCO International Year of Light, 2015.

You may wish to refer to the following Web site for more information and details: http://c.yimcdn.com/sites/www.eps.org/resource/resmgr/events/EPS_IYL2015prospectus.pdf

Please send your intentions to present for either the Saturday Paper Sessions or the Sunday IYL 2015 forum



**INTERNATIONAL
YEAR OF LIGHT
2015**

"An International Year of Light will allow the universality of light and the variety of its applications to be appreciated via many and varied themes covering broad areas of interest, supported by cross-cutting themes addressing essential issues to be included in all activities." The four main themes will be Light in Science, Technology, Nature, and Culture with the cross-cutting themes of Sustainability and Development, Education, History, and Young People."

to the following Web page. Deadline is 2014 April 15
<https://www.rasc.ca/events/call-for-papers>

If you have an questions please contact Program Chair Lauri Roche at pastpres@victoria.rasc.ca ★

Is your address correct? Are you moving?

If you are planning to move, or your address is incorrect on the label of your Journal, please contact the office immediately.

By changing your address in advance, you will continue to receive all issues of SkyNews and the Observer's Handbook.

(416) 924-7973

www.rasc.ca/contact

Fun With Arduinos—Part 1

Building an Autoguider



by Rick Saunders, London Centre
(ozzy@bell.net)

1. Description and building of the electronics

Microcontrollers such as the Atmel ATMEGA line can perform many very useful functions for amateur astronomers. Devices such as multi-channel anti-dew heat control, stepper-motor control, or auto-guiding interfaces are simple tasks for a small computer. When coupled with a simple-to-implement, open-source programming language and an inexpensive development platform, even the least tech-savvy of people can build useful devices in short order. The Arduino development system from Italy provides all of these.

Arduino started in 2005 as a project for students at the Interaction Design Institute Ivrea in Ivrea, Italy, but after the school shut down, the persons involved kept the project alive. Small programming boards for Atmel AVR microcontrollers were adopted as a standard and a programming language called *Wiring* was adapted to program the chips. Currently there are several “flavours” of official Arduino boards and lots of clones.

Expanding the line of development boards are a plethora of “shields,” offered by companies such as AdaFruit, that plug into the Arduino boards directly and carry ancillary logic to add capabilities such as wireless networking, GPS, and so on. The project that I will be discussing in this article—building an autoguider—is based on the Arduino Uno development board and a shield known as a “prototype shield.” This shield plugs into the Arduino and provides places to wire in chips and other parts that the Arduino can operate. Here we will use the prototype shield to build an auto-guider interface that can be used with *PHDGuide* or *MetaGuide* and a Webcam, to guide a telescope for astrophotography.

Figure 1 shows the front of the Arduino Uno development board with all of the pins that are available for use. Digital pins are those that can either be set to HIGH or LOW (5V or 0V) or can read a HIGH or a LOW. Some of these pins can be used for Pulse Width Modulation to run a DC motor at various speeds, set the brightness of an LED, or control anti-dew heat. Also shown are analogue pins, which are connected to an analogue-to-digital converter (ADC) that can be used to read sensors or potentiometers.

The Arduino Uno can be powered either through the USB connector, or by the power connector shown in Figure 1, if other voltages or higher currents are needed. The board

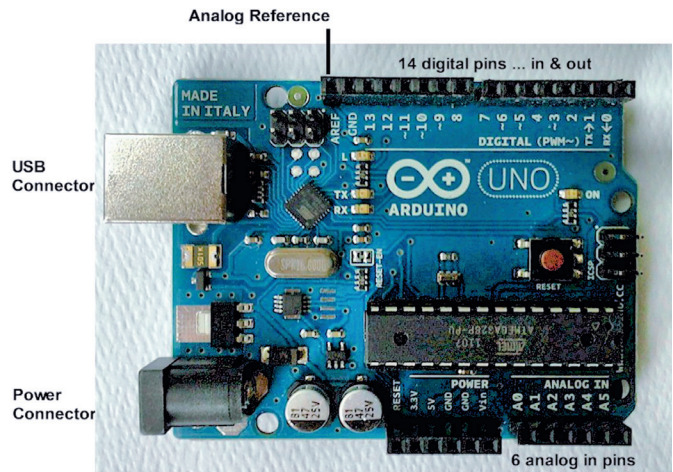

Figure 1 — The Arduino Uno with connections identified.

switches between power sources automatically (older boards needed a jumper moved) and has an on-board voltage regulator to provide the required 5V to the microcontroller. The USB connector is also used to program the microcontroller (the black chip at the lower right in Figure 1) from your computer; see the section on programming, below.

I am finished describing the Arduino; now on to the prototype shield. These boards are the same size and form factor as the Arduino development board (Figure 2). They plug into the female pin headers on the Arduino that are used to carry signals and voltages through to devices placed on the shield (the shield that I use is shown). All of the holes are plated through to the bottom of the shield, which makes them more robust. The connected holes in the shield make using IC chips simpler.

Before continuing, I will take a minute to explain how an autoguider works. Most mounts these days have an ST-4-compatible autoguider port. The ST-4 interface, developed by SBIG back in the 1990s, used an RJ12 6-wire modular connector with pin 2 on the connector connected to

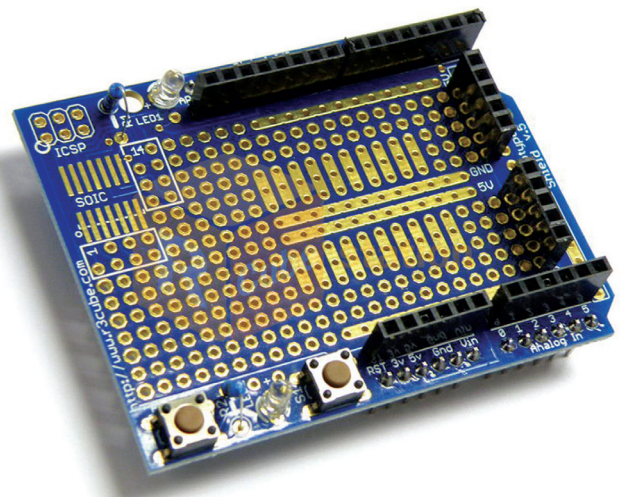

Figure 2 — The front of the Arduino prototype shield.

the telescope's ground and pins 3, 4, 5, and 6 connected to the telescope's processor to move the telescope left/right or up/down as needed.

The original ST-4 used relays (I have one and love it—the sound of the relays clicking is soothing somehow), but I will use something called an opto-coupler. Opto-couplers do the same job as the relays but in a much smaller and cheaper package. They also isolate the guider from the telescope. Opto-couplers have an internal LED and a photo-transistor. When the LED is illuminated, the transistor passes current. As the ST-4 standard just wants to ground a pin to activate the mount, a transistor is perfect for the job. The part I will use is called a PC847, which has four opto-coupler channels in a single chip, perfect for an autoguider.

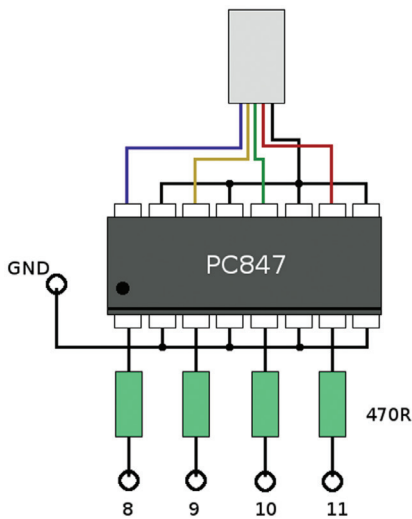

Figure 3 — Schematic of the wiring for the guider project.

Figure 3 shows the entire circuit that will be put on the prototype shield. The inputs to the PC847 are at the bottom. Each channel has a resistor on one leg and a connection to ground on the other. The microcontroller turns on (sets to HIGH) each leg as needed, and the resistor limits the current to the LED (we do not want to let the magic smoke out of the PC847, do we?). The PC847's outputs are at the top. When an LED turns on, the PC847 activates the appropriate transistor, which, at the other end, tells the telescope to move.

The build is fairly simple and comprises the soldering of a socket for the opto-coupler onto the prototype shield. When you do so, place it on the lines of connected through-holes (Figure 2), as this makes it simpler to install the other parts. To solder, place a hot iron against the part of the socket (or other part) extending through the bottom of the prototype shield for a few seconds, and then touch the solder to the hot joint. Keep the heat on the part after the solder has flowed in for a few seconds. Your finished solder joint should look shiny and have no voids.

Once the opto-coupler is in place, I find it simpler to remove one of the female pin headers on top of the prototype shield so that I can place the resistors (compare Figure 2 with Figure 4). Place 470-ohm resistors between the holes that are exposed when the pin-header is removed to the corresponding hole next to the 16-pin socket (Figure 4).

On the input side, notice that every other leg is connected to ground. While it is possible to run loops of wire, I find it simpler just to connect the leg to ground on the bottom of the prototype board (Figure 5). The long connected strip of holes labelled GND (Figure 2) is next to them and small bits of wire soldered across does the job. On the output side, I use small loops of wire to connect every other leg together to the “common” wire on the autoguider cable.

I solder the cable in place “captive” on the prototype board only to make it simpler to mount the complete unit into a suitable project box, a Hammond 1591 series case. The only cutouts that I had to put in it were a hole to let me plug a USB

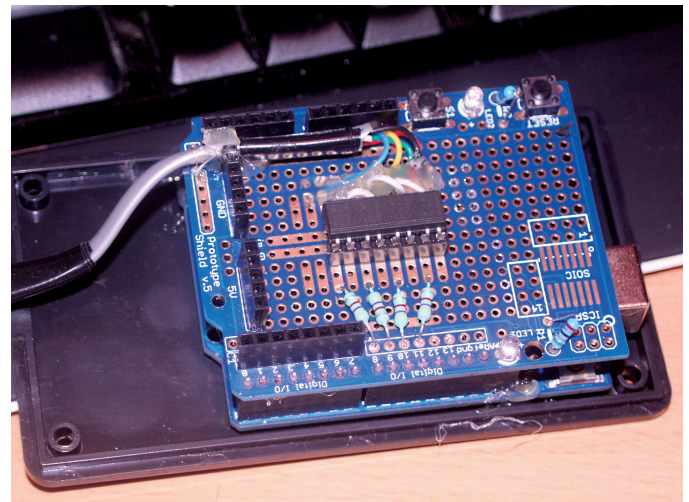

Figure 4 — The top of the prototype shield after wiring.

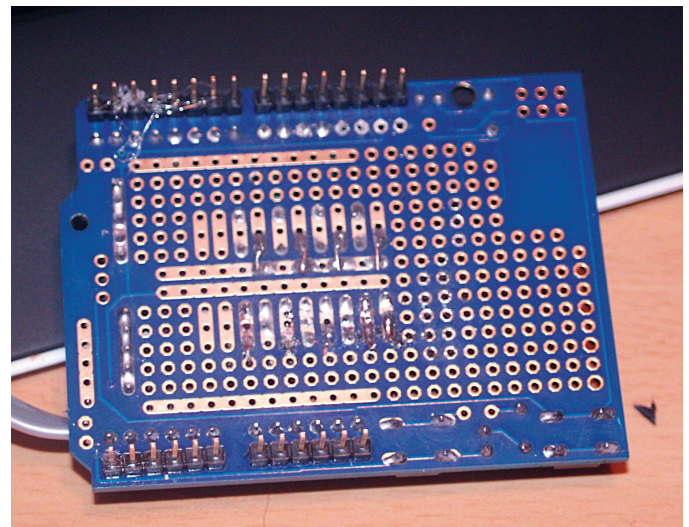

Figure 5 — The base of the prototype shield after wiring.

cable into the Arduino and then a small cutout at the other end to let the autoguider cable through.

To mount the Arduino in the case, I place the Arduino flat on the bottom and drill some small holes under the mounting holes. Then I insert some long, thin screws into the holes and place a dab of hot-glue on the case where the screws come through. These provide “stand offs” to keep the solder side of the Arduino raised a bit. Then I slide the Arduino onto the screws and put another dab of hot-glue onto the Arduino like a “nut” on each screw. To remove any hot-glue, use alcohol, as this breaks the surface tension and the hot-glue comes right off.



Figure 6 – The finished autoguider controller.

The finished unit is shown in Figure 6. While bulkier than Shoestring Astronomy’s GPUSB, it is a lot cheaper and works just as well.

2. Programming the device

The *Wiring* programming language provided by Arduino is at the heart of the system. Basically a re-wrapped C++, it simpli-

```
// Blink LED sketch
int LEDPin = 13;           // Select the pin to toggle
void setup () {
  pinMode( LEDPin, OUTPUT ); // Set the pint to output
}
void loop() {
  digitalWrite( LEDPin, HIGH ); // Turn on the LED
  delay( 500 );                 // Wait ½ a second
  digitalWrite( LEDPin, LOW ); // Turn off the LED
  delay( 500 );                 // Wait ½ a second
}
```

Figure 7 – Arduino script.

fies tasks to the point that one does not have to be a crack programmer to do useful things. Also, libraries of functions created by the Arduino community can simplify just about any programming task, from driving motors to reading sensors. Figure 7 is an example of an Arduino sketch (the language was originally designed for artists) that blinks an LED.

Every sketch has at least two functions, *setup* and *loop*. The setup function is run one time when the controller starts up. Then, the loop function runs over and over doing whatever it is told to do until the controller is reset or powered down. The *Wiring* language hides all of the underlying C++ code.

The sketch that I wrote to run the autoguider takes serial commands (LX200GPS/R compatible) and then activates the ST-4 guide system of the mount. It is much too large to include here, but I will make it available to anyone that wants to build one of these. It is natively supported by *MetaGuide* and *PHD* or you can use the Meade LX200GPS/R ASCOM driver. Get in touch with me at prez@rasclondon.ca for more information.

So, how much does this project cost?

PC847	5 pieces for \$7.35 (US)	eBay
Arduino Uno	With cable for \$9.90 (US)	eBay
Proto Shield	\$3.98 (US)	eBay
Hammond Case	\$5.75 A-1	Counterparts London
Resistors	20 for \$2.00	A-1 Counterparts London
Screws, wire, etc.	I had these on hand	
Total	About \$30 Canadian	(taxes in)

Having fun building a project? Priceless! ★

Rick Saunders became interested in astronomy after his father brought home a 50-mm refractor and showed him Saturn’s rings. Previously a member of both Toronto and Edmonton Centres, he now belongs to the London Centre and is mostly interested in DSLR astrophotography.

The Royal Astronomical Society of Canada is dedicated to the advancement of astronomy and its related sciences; the Journal espouses the scientific method, and supports dissemination of information, discoveries, and theories based on that well-tested method.

2014 RASC General Assembly



2014 June 26–29

Join the members of Victoria Centre as we commemorate 100 years of being a RASC Centre at our 2014 RASC General Assembly. To add to the festivities, we will also be celebrating the 100th anniversary of the Dominion Astrophysical Observatory, located in Saanich B.C., just to the north of downtown Victoria.

The 2014 General Assembly will showcase the DAO, the University of Victoria's new observatory located on the campus of our assembly's headquarters, and a wide-ranging scientific and cultural schedule of events for your family, all conducted against the spectacular natural beauty of Canada's West Coast. Guest speakers include Dr Laura Ferrarese, Bob McDonald of CBC's *Quirks and Quarks*, and the RASC's own Peter Broughton.

Victoria is serviced by both of our domestic air carriers and can be reached by convenient car ferry service connecting Victoria to Vancouver and Seattle, Washington.

From on-campus accommodation at the University of Victoria to nearby hotel and RV facilities, there are many lodging options available in the Greater Victoria for RASC members.

Registration goes live
March 1 at RASC.ca

Please join us in Victoria June 26–29!
RASC Victoria Centre

2014 General Assembly Organizing Committee

Mark Bohlman, Co-Chair mbohlman@shaw.ca
Paul Schumacher, Co-Chair docpschu@shaw.ca

Society News



by James Edgar, Regina Centre
(james@jamesedgar.ca)

In the February issue, I wrote “Watch for some important news in the new year about the new Fellow of the RASC award.” As many of you already know, the Awards Committee proposed to the Board that we kick off the new category of awards with three nominations: Randy Attwood, Dr. Roy Bishop, and Peter Broughton. Since that time, the Board has also approved awards for 2014 as follows:

Fellow of the RASC	James Hesser, Victoria
Chilton Prize	Kathryn Gray, Halifax; Nathan Gray, Halifax
Qilak Award	Dr. Howard Trotter, Vancouver
Service Award	Jay Anderson, Winnipeg; Susan Gagnon, Kingston; Dave Gamble, Okanagan; Dr. James Hesser, Victoria; Greg Lisk, Belleville; Chris Stevenson, St. John's; Mary Lou Whitehorne, Halifax

I'm also pleased to report that the Board has accepted and approved the report of the NAC Working Group that explored the possibility of including or inviting committee chairs, editors, the Honorary President, and the Past President to attend NAC meetings. Financial support for the foregoing has also been approved at the February 9 Board meeting. ★

Solar Eclipses Crossword Answers

by Naomi Pasachoff

	S	U	D		F	A	R	M		C	H	O	R	D	
D	O	N	E		A	R	E	A		R	E	R	U	N	
E	V	R	A		L	A	N	D		U	M	B	R	A	
B	A	I	L	Y	S	B	E	A	D	S					
T	I	P	T	O	E			M	A	T		B	R	A	
S	N	E		U	T	E	S		H	Y	B	R	I	D	
				A	T	T	L	E	E			L	E	T	S
		P	I	N	H	O	L	E	C	A	M	E	R	A	
F	O	N	T				A	I	R	P	O	D			
O	U	T	S	E	T		T	U	R	N		B	A	T	
P	R	O			S	O	B			I	D	I	O	M	S
					S	O	L	A	R	C	O	R	O	N	A
L	A	U	R	A			O	R	E	O		A	M	O	R
A	R	R	A	Y			T	I	N	T		N	E	T	S
B	A	N	D	S			S	A	T	S		I	R	A	

Astrocryptic

by Curt Nason

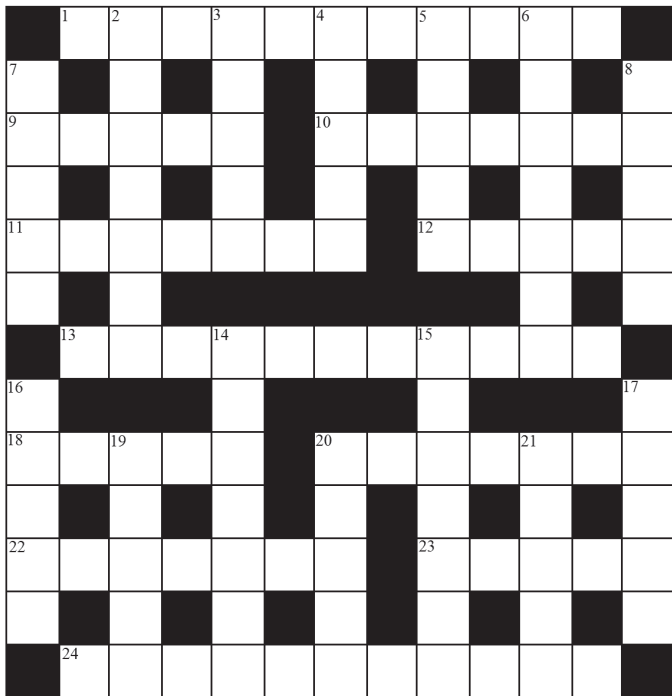

ACROSS

1. Make repeated example that's round, goes round, doesn't round up (5,6)
9. One on your house may be bad and otherworldly (5)
10. Lumber one can use to build a satellite (7)
11. Sleeman owner in the main belt (7)
12. Light ones are long revolutionary periods (5)
13. Engine charges without argon mixture for counter glow (11)
18. Godzilla's ally had a vowel movement due to gas (5)
20. Despot tumbled after start of rebellious storm (3,4)
22. Oddly, Mars apt to be absent in this chart (4,3)
23. It sounds like a top quality binocular (5)
24. Bewildering mortals, Ross flares (5,6)

DOWN

2. He studied comets while going around very quietly (7)
3. He has a starry asteroid and a pulled groin (5)
4. Underworld boss in the outer world (5)
5. Observing ridge near Halifax by 3D's road (5)
6. Returns in a dire situation from the river (7)
7. Lunar feature discovered in Palomar's Hale telescope (5)
8. Rock in rock in pyroclastic formation (5)
14. Asteroid family is bad omen with IAU mix-up (7)
15. Algol mostly hid before its discovery by Baade (7)
16. Angry feature of the northern and southern skies (5)
17. Supporter of the Pleiades and the sky (5)
19. Doctor a company with its head at the foot of Hercules (5)
20. Super spinning scarp (5)
21. Knight rides back in the afternoon for a light bender (5)

Answers to February's Astrocryptic

Curt Nason has provided *Journal* readers with Astrocryptic puzzles for as long as the Editor can remember—somewhere back about 15 years ago. Some of our readers are determined *conquistadors*, tackling every puzzle as soon as their copy arrives. But for most of us, the puzzles are... a puzzle. How do they work?

First of all, there are a lot of anagrams in the Astrocryptics. To borrow from Wikipedia, "An anagram is a type of word play, the result of rearranging the letters of a word or phrase to produce a new word or phrase, using all the original letters exactly once." To see how Curt's mind works, here are the answers for February's Astrocryptic, with explanations (you'll have to look back at February for the clues):

Across:

- 2 HYAKUTAKE (anagram + U);
- 8 VEGAS (2 defs);
- 9 DOPPLER (anag + R);
- 10 JANSSEN (hidden *Trojans sentry*);
- 11 ARNEB (hidden);
- 12 YES MAN (Y + anag);
- 14 ADHARA (ad + H + Ara);
- 18 FOVEA (fov + each);
- 20 CAPTURE (Ca + anag);
- 22 SERPENT (anag);
- 23 ATRIA (2 def);
- 24 OORT Cloud (anag + loud)

Down:

- 1 LOVEJOY (2 def);
- 2 HYGINUS (H + rev);
- 3 APSIS (hid rev);
- 4 UNDINA (hid);
- 5 ALPHARD (a + RD);
- 6 ELLEN (hid);
- 7 ACRAB (a C(RA)B);
- 13 AMATEUR (anag);
- 15 AQUARID (a+Q+u+arid);
- 16 AVERAGE (anag);
- 17 ACETIC (hid + C);
- 18 FOSSA (rev hid + salt);
- 19 VIRGO (VI + R + go);
- 21 PLATO (P(lat)o)

To get you started, the clue for 2 across is "A great comet finder manoeuvred the kayak around university (9)." The (9) at the end is the number of letters. The explanation above is "anagram + U," which leads to the critical letters from the sentence: ... The kayak ... plus the letter "U," to construct "Hyakutake." Easy, once you see how it's done. Now try this month's challenge. If you want to warm up on something more conventional, try Naomi Pasachoff's crossword on galaxies. ★

RASC members receiving this *Journal* in electronic format are hereby granted permission to make a single paper copy for their personal use.

THE ROYAL ASTRONOMICAL SOCIETY OF CANADA

Board of Directors and appointed officers for 2014 | Conseil d'administration et membres attitrés pour 2014

Honorary President

John R. Percy, Ph.D., Toronto

President

Glenn Hawley, B.Sc., B.Ed., Calgary

1st Vice-President

Colin Haig, B.Sc., M.Sc., Hamilton

2nd Vice-President

Chris Gainor, B.A., M.Sc., Ph.D., Victoria

Secretary

James Edgar, Regina

Treasurer

Denis Grey, B. Math., M.B.A., Toronto

Director

Paul Gray, Halifax

Director

Francois van Heerden, Toronto

Director

Paul Schumacher, D.D.S., M.T.S., Victoria

Past President

Mary Lou Whitehorne, Halifax

Executive Director

Deborah Thompson, CAE, Society Office

Editors

Journal

Jay Anderson, B.Sc., MNRM, Winnipeg

Observer's Handbook

David M.F. Chapman, M.Sc., Halifax

Beginner's Observing Guide

Brenda Shaw, Toronto

eBulletin

Dave Garner, B.Sc., M.o.A., Kitchener-Waterloo

Observer's Calendar

Paul Gray, Halifax

Great Images



Kevin Black shot this image of NGC 3718 from "The Pit" northeast of Winnipeg last spring. NGC 3718 is a twisted spiral galaxy in Ursa Major with a prominent red core and equally impressive blue arms that stretch above and below in this greyscale image. The companion galaxy to the upper left, NGC 3729, is believed to be responsible for the distorted appearance of 3718. Exposure was 10x6 minutes on a 10-inch $f/8$ Ritchey-Chrétien telescope using a Canon 60Da camera at ISO 1600.



Journal

Great Images

NGC 891 is a charming edge-on spiral galaxy lying at a distance of 31 Mly in Andromeda. The galaxy is noteworthy for its prominent dusty disk and its similarity to our own galaxy, in mass and appearance. Dalton Wilson captured this image from Didsbury, Alberta, using an AstroTech 10" f/8 Ritchey-Chrétien telescope and a QSI 540wsg camera. Exposure was 9×600 in RGB, and 10×900 in L at a temperature of -36 °C.